



FINAL DRAFT MINUTES

July 20, 2023 Standards Committee Meeting

(Changes to the Agenda by the Action of the Committee shown as highlighted in yellow, and based on comments received - in green)

August 11, 2023

TO: Standards Committee

FROM: Scott Trammell, Secretary

RE: Minutes from the July 20, 2023 Standards Committee Meeting

The July Standards Committee meeting was called to order by Mr. Pankow, Chair, at 09:00 a.m. on July 20, 2023, which was held virtually via *Teams* (Microsoft application). The meeting was adjourned at 10:47 a.m.

The following committee members were in attendance:

Pankow, Gregory, Chairman, Director, Construction Management
Bruno*, Joseph, Traffic Engineering
Dave, Kumar, Pavement Engineering
Koch, Mike, District Construction, Fort Wayne District
Novak, Joseph, Construction Management
Orton, Mark, Highway Engineering
Pelz, Kurt, Construction Technical Support
Rearick, Anne, Engineering and Asset Management
Reilman, Jim, Division of Materials and Tests
White, Peter, Bridge Engineering
Wooden, John, Division of Contract Administration
* Proxy for Boruff, Dave

Also, the following attendees were present:

Bazlamit, Subhi M, INDOT
Blanchard, Jacob, INDOT
Coffin, Tamara (Delaney), INDOT
Couch, Gregory, INDOT
Cruz, Elena, INDOT

Kachler, Mischa, INDOT
Korff, Jon, INDOT
Mouser, Elizabeth, INDOT
Nelson, Mike, INDOT
Patterson, Patrick, INDOT

Duncan, Thomas, FHWA
Feutz, Douglas, INDOT
Fisher, Steve, INDOT
Galetka, Jason, INDOT
Hailat, Mahmoud, INDOT
Harris, Tom, INDOT
Hauser, Derrick, INDOT
Jacobs, David L, INDOT

Perugu, Kshitija, INDOT
Reedy, Joseph, INDOT
Ritter, John, INDOT
Russell, Melissa, INDOT
Smutzer, Katherine, INDOT
Thornton, Donald, INDOT
Trammell, Scott, INDOT
Turk, Aamir, INDOT

The following items were discussed:

A. GENERAL BUSINESS

OLD BUSINESS

(No items were listed)

NEW BUSINESS

1. *Approval of the Minutes from the [June 15, 2023](#) meeting*

Mr. Pankow requested a motion to approve the Minutes from the June 15, 2023 meeting.

Motion: Mr. Novak
Second: Mr. Pelz
Ayes: 10
Nays: 0

ACTION:

PASSED AS SUBMITTED

B. CONCEPTUAL PROPOSAL

(No items were listed)

C. STANDARD SPECIFICATIONS, SPECIAL PROVISIONS, AND STANDARD DRAWINGS PROPOSAL

OLD BUSINESS

[Item No. 1 \(05/18/2023\)](#) [Mr. Novak](#) [pg. 5](#)

2024 Standard Specifications:

108.04	Prosecution of the Work
801.03	General Requirements
801.10	Temporary Traffic Barriers
801.10.1	Construction Zone Energy Absorbing Terminal, CZ

Standard Drawings:

E 801-TCCB-01	TEMPORARY CONCRETE BARRIER INDEX SHEET
---------------	--

E 801-TCCB-02	TEMPORARY CONCRETE BARRIER DIMENSIONS
E 801-TCCB-03	TEMPORARY CONCRETE BARRIER DETAILS
E 801-TCCB-04	TEMPORARY CONCRETE BARRIER DOUBLE TAPER END SECTION
E 801-TCCB-05	ANCHORED TEMPORARY CONCRETE BARRIER, DROP-IN ANCHOR
E 801-TCCB-06	ANCHORED TEMPORARY CONCRETE BARRIER, FERRULE LOOP INSERT

ACTION:	PASSED AS REVISED
----------------	--------------------------

NEW BUSINESS

<u>Item No. 1</u>	<u>Mr. Reilman</u>	<u>pg. 33</u>
-------------------	--------------------	---------------

2024 Standard Specifications:

735.03	Design Criteria
910.07	Steel Components of MSE Retaining Walls

ACTION:	PASSED AS REVISED SUBMITTED
----------------	------------------------------------

<u>Item No. 2</u>	<u>Mr. Reilman</u>	<u>pg. 37</u>
-------------------	--------------------	---------------

2024 Standard Specifications:

211.02	Materials
--------	-----------

ACTION:	WITHDRAWN
----------------	------------------

<u>Item No. 3</u>	<u>Mr. White</u>	<u>pg. 42</u>
-------------------	------------------	---------------

2024 Standard Specifications:

609.02	Materials
--------	-----------

Standard Drawing:

E 609-BRJT-01	TYPE I-A JOINT
---------------	----------------

ACTION:	PASSED AS REVISED
----------------	--------------------------

<u>Item No. 4</u>	<u>Mr. Reilman</u>	<u>pg. 49</u>
-------------------	--------------------	---------------

2024 Standard Specifications:

502.04	Concrete Mix Criteria
506.06	Job Control
506.12	Opening to Traffic

ACTION:	PASSED AS SUBMITTED
----------------	----------------------------

Item No. 5 Mr. Reilman pg. 55

2024 Standard Specifications (changes to various subsections)

SECTION 101	DEFINITIONS AND TERMS
SECTION 104	SCOPE OF WORK
SECTION 202	REMOVAL OF STRUCTURES AND OBSTRUCTIONS
SECTION 203	EXCAVATION AND EMBANKMENT
SECTION 604	SIDEWALKS, CURB RAMPS, STEPS, AND HANDRAILS
SECTION 619	COATING BRIDGE STEEL
SECTION 711	STEEL STRUCTURES
SECTION 712	TIMBER STRUCTURES
SECTION 729	HEAT STRAIGHTENING OF STEEL MEMBERS IN THE FIELD
SECTION 801	TRAFFIC CONTROLS FOR CONSTRUCTION AND MAINTENANCE OPERATIONS
SECTION 802	SIGNS
SECTION 805	TRAFFIC SIGNALS
SECTION 807	HIGHWAY ILLUMINATION
SECTION 909	COATINGS, PAINTS, AND LIQUID EPOXY

Recurring Special Provisions:

619-B-314	ALTERNATE FINISH COAT FOR PARTIAL PAINT SYSTEM (<i>PROPOSED TO DISCONTINUE</i>)
620-R-483	SOUND BARRIER SYSTEMS

ACTION: **PASSED AS REVISED**

Item No. 6 Mr. Reilman pg. 113

2024 Standard Specifications:

509.05	Quality Control Plan
509.14	Job Control

ACTION: **PASSED AS SUBMITTED**

Item No. 7 Mr. Reilman pg. 117

2024 Standard Specifications:

715.02(i)	Underdrain Outlet Pipe
715.02(l)	Roadway Drain Casting Extensions
907.16	Thermoplastic Pipe Requirements
907.24(b)	Schedule 40 PVC Pipe

ACTION: **PASSED AS SUBMITTED**

cc: Committee Members
FHWA
ICI

PROPOSAL TO STANDARDS COMMITTEE

PROBLEM(S) ENCOUNTERED: 801.10 has allowed modifications to terminating temporary traffic barrier when field conditions do not allow placement per the construction plans. These modifications to flare rates or termination points without CZ units are being made in the field, many times without approval by the designer. These types of safety modifications should be conservative or reviewed and approved by the designer. 801.03 describes the devices that are to be inspection by the CWTS, which currently excludes the temporary traffic barrier.

PROPOSED SOLUTION: Within 801.10, delete the existing language that allows extreme modification of the flare rate and offset of the termination point of temporary traffic barrier and add in more descriptive termination allowances.

Along with the abovementioned deletions and additions, edits have been proposed for being more consistent with the terms segment for temporary traffic barrier and unit for CZ units.

In addition, clarify how type 1, type 2, type 3, and type 4 temporary traffic barrier and CZ units can be applied and criteria the devices should meet. Within 801.03, propose to require the CWTS to be responsible for the condition of the temporary traffic barrier by deleting the exception of the temporary traffic barrier and require the CWTS to provide a copy of the ATSSA Quality Standards for Temporary Traffic Control Devices booklet when requested by the Engineer.

To keep language clarifications consistent throughout the section, RSP, and standard drawings, proposed revisions for RSP 801-T-207 and Standard Drawing series 801-TCCB.

APPLICABLE STANDARD SPECIFICATIONS: 801.10 and 801.03

APPLICABLE STANDARD DRAWINGS: 801-TCCB Series

APPLICABLE DESIGN MANUAL SECTION: 503-3.05(04) and (05)

APPLICABLE SECTION OF GIFE: 2.8, 21.2

APPLICABLE RECURRING SPECIAL PROVISIONS: RSP 801-T-207

PAY ITEMS AFFECTED: N/A

APPLICABLE SUB-COMMITTEE ENDORSEMENT: Ad-Hoc Committee: Joe Novak, John Ritter, Elizabeth Mouser, Dan Osborn (ICI), and Katherine Smutzer

IF APPROVED AS RECURRING SPECIAL PROVISION OR PLAN DETAILS, PROPOSED BASIS FOR USE: Required for all contracts with pay item 801-08400 Temporary Traffic Barrier Type 1, 801-08401 Temporary Traffic Barrier Type 2, 801-08402 Temporary Traffic Barrier Type 3, 801-08403 Temporary Traffic Barrier Type 4, 801-08507 Temporary Traffic Barrier Anchored Type 1, 801-08508 Temporary Traffic Barrier Anchored Type 2, 801-08509 Temporary Traffic Barrier Anchored Type 3.

STANDARD SPECIFICATIONS, SPECIAL PROVISIONS AND STANDARD DRAWINGS

REVISION TO STANDARD SPECIFICATIONS AND STANDARD DRAWINGS

IMPACT ANALYSIS (attach report): yes

Submitted By: Katherine Smutzer

Title: Work Zone Safety Engineer

Division: Traffic Management

E-mail: ksmutzer@indot.in.gov

Date: 4/24/2023

FINAL DRAFT MINUTES

IMPACT ANALYSIS REPORT CHECKLIST

Explain the business case as to why this item should be presented to the Standards Committee for approval. Answer the following questions with Yes, No or N/A.

Does this item appear in any other specification sections? No

Will approval of this item affect the Qualified Products List (QPL)? No

Will this proposal improve:

Construction costs? No

Construction time? No

Customer satisfaction? Yes

Congestion/travel time? No

Ride quality? No

Will this proposal reduce operational costs or maintenance effort? No

Will this item improve safety:

For motorists? Yes

For construction workers? Yes

Will this proposal improve quality for:

Construction procedures/processes? Yes

Asset preservation? No

Design process? No

Will this change provide the contractor more flexibility? No

Will this proposal provide clarification for the Contractor and field personnel? Yes

Can this item improve/reduce the number of potential change orders? No

Is this proposal needed for compliance with:

Federal or State regulations? No

AASHTO or other design code? No

Is this item editorial? No

Provide any further information as to why this proposal should be placed on the Standards Committee meeting Agenda:

REVISION TO STANDARD SPECIFICATIONS AND STANDARD DRAWINGS

SECTION 108 – PROSECUTION AND PROGRESS

108.04 Prosecution of the Work

SECTION 801 – TRAFFIC CONTROLS FOR CONSTRUCTION AND MAINTENANCE OPERATIONS

801.03 General Requirements

801.10 Temporary Traffic Barriers

801.10.1 Construction Zone Energy Absorbing Terminal, CZ

(Note: Proposed changes shown highlighted gray.
Previously approved changes shown shaded and are in provision:
[801-T-207 Temporary Traffic Barriers](#)

The Standard Specifications are revised as follows:

SECTION 108, BEGIN LINE 211, DELETE AND INSERT AS FOLLOWS:

Temporary drainage structures, temporary ~~concrete median~~ traffic barriers, and other temporary devices required and used for the maintenance of traffic shall remain the property of the Contractor. All costs for furnishing, placing, maintaining, removal, and disposal of temporary drainage structures shall be included in the contract lump sum price for maintaining traffic. If there is no pay item for maintaining traffic, these costs shall be included in the various pay items listed in the proposal, unless otherwise provided.

SECTION 801, BEGIN LINE 70, DELETE AND INSERT AS FOLLOWS:

801.03 General Requirements

The applicable requirements of the MUTCD shall apply to the installation and materials for traffic control devices subject to the requirements of 107.08 and 107.12. When the plans do not include a maintenance of traffic plan, the Engineer will provide such a plan to the Contractor. The Contractor shall be responsible for the field layout, placement, operation, maintenance, and removal of temporary traffic control devices.

A worksite traffic supervisor certified by the American Traffic Safety Service Association, ATSSA, or approved equal certifying organization, shall direct all field layout, placement, operation, inspection, maintenance, and removal of temporary traffic control devices. The certified worksite traffic supervisor, CWTS, shall ensure that all traffic control devices ~~except temporary concrete barrier~~, meet acceptable standards as outlined in the plans, specifications, and ATSSA's "Quality Standards for Temporary Traffic Control Devices" prior to installation. *A copy of the ATSSA's "Quality Standards for Temporary Traffic Control Devices" shall be provided to the Engineer upon request.* The CWTS shall also, prior to installation, ensure that all traffic control devices can be installed in accordance with the plans, specifications, and the MUTCD. All problems shall be reported to the Engineer so a resolution can be worked out prior to installation. The field layout will be reviewed and is subject to approval by the Engineer prior to placement of any temporary traffic control devices. The CWTS shall be present for the initial setup and all phase changes during the life of the project. The CWTS may designate responsible Contractor personnel to perform day to day operation, inspection, and maintenance of the temporary traffic control devices. These responsible personnel shall work under the direction of the CWTS and their names shall be given to the Engineer on the project. A copy of the CWTS's certification shall be provided to the Engineer prior to the start of construction or placement of temporary traffic control devices or if the worksite traffic supervisor changes.

REVISION TO STANDARD SPECIFICATIONS AND STANDARD DRAWINGS

SECTION 108 – PROSECUTION AND PROGRESS

108.04 Prosecution of the Work

SECTION 801 – TRAFFIC CONTROLS FOR CONSTRUCTION AND MAINTENANCE OPERATIONS

801.03 General Requirements

801.10 Temporary Traffic Barriers

801.10.1 Construction Zone Energy Absorbing Terminal, CZ

SECTION 801, BEGIN LINE 186, DELETE AND INSERT AS FOLLOWS:

Temporary drainage structures, temporary concrete median traffic barrier units, and other temporary devices required and used for traffic maintenance shall remain the property of the Contractor.

SECTION 801, BEGIN LINE 131, INSERT AS FOLLOWS:

Except for construction warning lights and temporary signals, the ATSSA brochure titled “Quality Guidelines for Temporary Traffic Control Devices and Features” will be used as a guide to determine if temporary traffic control devices and markings are Acceptable, Marginal, or Unacceptable. Upon initial setup and phase changes of temporary traffic control devices, all individual devices shall be of the Acceptable classification. A device not completely covered or removed when the message does not apply or when directed, will be considered unacceptable.

A temporary traffic control device will be deemed to be in non-compliance when considered Unacceptable. A type of temporary traffic control device will be deemed to be in non-compliance when 25% or more of the individual devices *or temporary concrete barrier segments* are considered Marginal. Damages may be assessed in accordance with 105.14 for non-compliance.

The quality assurance unit for placed temporary concrete barrier shall be the total number of segments installed. Temporary concrete barrier segments that are deemed non-compliant shall be promptly repaired or replaced.

SECTION 801, BEGIN LINE 354, DELETE AND INSERT AS FOLLOWS:

801.10 Temporary Traffic Barriers

Temporary traffic barrier shall be one of the following four types as shown on the plans.

The application for each temporary traffic barrier type shall be as follows:

<i>Temporary Traffic Barrier Type Designation</i>	<i>Application</i>
<i>Type 1</i>	<i>Used to separate two-way traffic</i>
<i>Type 2</i>	<i>Used to separate traffic from the work zone</i>
<i>Type 3</i>	<i>Used in the same manner as Type 1 and remains in place after contract completion.</i>

REVISION TO STANDARD SPECIFICATIONS AND STANDARD DRAWINGS

SECTION 108 – PROSECUTION AND PROGRESS

108.04 Prosecution of the Work

SECTION 801 – TRAFFIC CONTROLS FOR CONSTRUCTION AND MAINTENANCE OPERATIONS

801.03 General Requirements

801.10 Temporary Traffic Barriers

801.10.1 Construction Zone Energy Absorbing Terminal, CZ

Type 4	<i>Used to accommodate the closing or shifting of traffic lanes on a daily basis to better facilitate the changing volumes of traffic during the peak hours of a day.</i>
--------	---

Type 1

~~Type 1 temporary traffic barriers shall be used to separate two-way traffic and barriers used as ~~†~~Type 1 temporary traffic barrier shall be precast concrete in accordance with applicable requirements of 707 and 602 and as shown on the plans. Type 1 barriers may also be used to separate traffic from the work area. Barriers acceptable for use as ~~†~~Type 1 may also be used as ~~†~~Type 2.~~

[moved to separate paragraph] The surfaces of individual precast concrete units barrier segments shall vary no more than 1/4 in. in 10 ft from the specified cross-section, as measured from a longitudinal straightedge. The maximum variation in the vertical and horizontal alignment of adjacent units abutting segments shall be 1/4 in. across the joint, as measured from a 10 ft longitudinal straightedge. Sections that have obvious defects or visual cracks shall not be used. Sections that develop any of these conditions during the contract shall be repaired with concrete or replaced within a reasonable amount of time. Segment condition and maintenance shall be in accordance with 801.03.

~~Type 1 barrier units precast prior to 2003 shall not be used after January 1, 2012. Units precast after March 1, 2003 Precast concrete barrier segments manufactured prior to March 1, 2003 shall not be used. Each barrier segment shall be clearly marked with the name or trademark of the manufacturer, the year of manufacture, and “INDOT”. The markings shall be indented on an end or on the top of each barrier section segment. Units precast Segments manufactured after January 1, 2007 shall be from the QPL of Certified Precast Concrete Producers.~~

Type 2

~~Type 2 barriers may be used to separate traffic from the work area. Type 2 temporary traffic barriers shall meet the appropriate test level 2 or 3 MASH or NCHRP 350 or MASH crash test standards and shall be approved for use by the FHWA criteria. A copy of the MASH or NCHRP 350 crash test FHWA eligibility letter shall be provided to the Engineer prior to placing the unit report confirming the product is NCHRP 350 or MASH compliant for the test level specified, or a copy of the FHWA eligibility letter, shall be furnished to the Engineer prior to the installation of the barrier.~~

[moved to a separate paragraph] The unit barrier selected shall be appropriate for the location considering the maximum posted speed limit on the project prior to construction and the allowable area for deflection. The unit barrier shall be installed according to the manufacturer’s recommendations.

REVISION TO STANDARD SPECIFICATIONS AND STANDARD DRAWINGS

SECTION 108 – PROSECUTION AND PROGRESS

108.04 Prosecution of the Work

SECTION 801 – TRAFFIC CONTROLS FOR CONSTRUCTION AND MAINTENANCE OPERATIONS

801.03 General Requirements

801.10 Temporary Traffic Barriers

801.10.1 Construction Zone Energy Absorbing Terminal, CZ

If concrete barriers are used as Type 2 barriers, they shall be in accordance with the requirements for Type 1 barriers. Barriers acceptable for use as Type 1 may also be used as Type 2.

Type 3

Type 3 temporary traffic barriers shall be those Type 1 temporary traffic barriers that are to be used as Type 3 temporary traffic barrier shall be in accordance with the requirements for barrier used as Type 1. They shall be left in place at the completion of the contract and shall become the property of the Department. They shall be in like-new condition at the completion of the contract. All necessary delineation and required anchor systems shall be left in place.

Type 4

Type 4 temporary traffic barriers shall be those types that are intended to be readily moveable to accommodate the shifting of traffic lanes on a daily basis to better facilitate the changing volumes of traffic during the peak hours of a day. Barrier used as Type 4 temporary traffic barriers shall be readily moveable and meet the appropriate test level 3 MASH or NCHRP 350 or MASH crash test criteria standards and shall be approved for use by the FHWA. A copy of the MASH or NCHRP 350 crash test FHWA eligibility letter shall be provided to the Engineer prior to placing the unit report confirming the product is NCHRP 350 or MASH compliant for the test level specified, or a copy of the FHWA eligibility letter, shall be furnished to the Engineer prior to the installation of the barrier.

(a) Placement

Temporary traffic barriers shall be located as shown on the plans or as directed. Temporary traffic barriers used to close a lane of traffic shall be flared at the rates as shown on the plans for the applicable regulatory speed within the construction zone. If field conditions are such that the required flare rate cannot be utilized, the tapered alignment may be altered, with approval, to a 10:1 flare rate with a 20 ft minimum offset from the edge of the through traffic lane to the approaching end of the flared temporary traffic barrier. If field conditions are such that that the 10:1 flare rate cannot be utilized, the tapered alignment may be further altered, with approval, to a 6:1 flare rate with the 20 ft minimum offset. Flare rates for ends of temporary traffic barriers at locations where a lane of traffic is not being closed to traffic or where the lane has already been closed shall be the same as above, however the minimum offset from the edge of the through traffic lane may be 10 ft. The use of flare rates sharper than those shown on the plans may require additional traffic control devices as directed. Each run of temporary traffic barrier shall be installed and maintained such that abutting segments form a smooth continuous plane, except for the start and end of a flared section.

REVISION TO STANDARD SPECIFICATIONS AND STANDARD DRAWINGS

SECTION 108 – PROSECUTION AND PROGRESS

108.04 Prosecution of the Work

SECTION 801 – TRAFFIC CONTROLS FOR CONSTRUCTION AND MAINTENANCE OPERATIONS

801.03 General Requirements

801.10 Temporary Traffic Barriers

801.10.1 Construction Zone Energy Absorbing Terminal, CZ

The cross slope or side slope leading to and on which temporary traffic barrier is placed shall be 10:1 or flatter. For roadways other than freeways or interstates, if field conditions are such that the required slopes cannot be utilized, the temporary traffic barrier may be placed on a side slope of no steeper than 4:1, subject to approval prior to placement.

Temporary traffic barrier shall be flared at the rates as shown on plans for the applicable regulatory speed within the construction zone.

Where temporary traffic barrier is exposed to oncoming traffic and the approaching end is within the construction clear zone distance as shown on plans, an appropriate end treatment shall be placed in accordance with 801.10(e). Where required slopes and barrier flare rates are satisfied, the barrier may be extended beyond the construction clear zone distance without an end treatment.

Where temporary traffic barrier is placed adjacent to the front face of guardrail or concrete barrier, the approaching end of the temporary traffic barrier, including the end treatment, shall overlap a minimum distance beyond the end of the guardrail or concrete barrier as follow:

- 1. 15 ft if adjacent guardrail terminated with a crashworthy end treatment,*
- 2. 40 ft if adjacent guardrail terminated with a cable terminal anchor,*
- 3. 100 ft if adjacent concrete barrier or cut guardrail.*

Where temporary traffic barrier is placed behind guardrail, no portion of the barrier shall be within 10 ft, measured from the front face of the guardrail. The approaching end of the barrier shall overlap a minimum distance beyond the end of the guardrail as described above. If field conditions are such that the required slopes or flare rate cannot be utilized, the temporary traffic barrier shall be placed adjacent to the front face of guardrail as described in this section.

~~*Type 2 barriers shall not be intermixed with Type 1 or Type 3 barriers in any run. Type 2 barriers from different manufacturers shall not be intermixed in any run.*~~

Precast concrete barriers shall not be intermixed with precast concrete barriers of a different size or shape or with any non-concrete barrier in any run. Non-concrete barriers shall not be intermixed with barriers from different manufacturers in any run.

[\[see RSP 801-T-207\]](#)

(b) Connection

REVISION TO STANDARD SPECIFICATIONS AND STANDARD DRAWINGS

SECTION 108 – PROSECUTION AND PROGRESS

108.04 Prosecution of the Work

SECTION 801 – TRAFFIC CONTROLS FOR CONSTRUCTION AND MAINTENANCE OPERATIONS

801.03 General Requirements

801.10 Temporary Traffic Barriers

801.10.1 Construction Zone Energy Absorbing Terminal, CZ

Precast concrete barriers used as Type 1, Type 2, and or Type 3 temporary traffic barriers sections shall be connected as shown on the plans and as follows:

1. Smooth Bar Hooks

- 1a. The adjacent abutting barrier sections segments shall be placed end to end, with sufficient overlapping of the smooth bar hooks to allow placement of the connecting bolt or threaded rod and the top spacer.
- 2b. The adjacent abutting sections segments shall then be moved in opposite directions for a sufficient distance to develop the maximum contact between the smooth bar hooks and the connecting bolt or threaded rod.
- 3c. The bottom spacer and nut shall then be placed as shown on the plans. The nut shall be sufficiently tightened to eliminate all gaps between the adjacent bolt heads, spacers, nuts, and washers which form the connection.

2. J-J Hook

- a. The adjacent abutting barrier sections segments shall be placed in accordance with the manufacturer's recommendations such that the J-J hooks are engaged.
- b. The adjacent abutting barrier sections segments shall then be moved in opposite directions for a sufficient distance to develop the maximum separation between the barrier sections.

Type 1 and Type 3 precast units which have previously been cast meeting earlier Department standards may be used. The Contractor will be allowed to mix Type 1 and Type 3 units in a run as long as the units are in good condition and the connecting devices are compatible. If units meeting earlier Department standards are used, a 1 in. bolt will be allowed to link the units together. The spacer detail shall, however, be in accordance with the current standard. Units cast after March 1, 2003 shall be linked with the 1 1/4 in. bolt. Precast concrete barrier connecting devices shall not be intermixed.

Type 2 Temporary traffic barriers other than precast concrete as described as Type 1 shall be connected as recommended by the barrier manufacturer.

REVISION TO STANDARD SPECIFICATIONS AND STANDARD DRAWINGS

SECTION 108 – PROSECUTION AND PROGRESS

108.04 Prosecution of the Work

SECTION 801 – TRAFFIC CONTROLS FOR CONSTRUCTION AND MAINTENANCE OPERATIONS

801.03 General Requirements

801.10 Temporary Traffic Barriers

801.10.1 Construction Zone Energy Absorbing Terminal, CZ

(c) Anchorage

~~Type 1 and Type 3 temporary traffic barriers shall be anchored in accordance with the methods shown on the plans, at the locations described herein. Type 2 barriers shall be anchored as recommended by the barrier manufacturer and at locations described herein. Temporary concrete traffic barriers shall be anchored when located on or within 60 ft of a bridge, and along tapered alignments at the locations shown on the plans. Anchoring at locations in addition to those described herein will shown shall be required when directed. Anchoring shall be in accordance with the NCHRP 350 or MASH crash test. The FHWA eligibility letter shall be provided to the Engineer prior to placing the barrier. Anchoring for precast concrete barriers described as Type 1 shall be as shown on the plans.~~

Anchoring all other barriers shall be in accordance with the associated NCHRP 350 or MASH crash test. A copy of the anchorage installation details shall be furnished to the Engineering prior to installation of the barrier.

Chemical anchor systems with removable bolts, or mechanical anchors may be used to anchor Type 1 barriers to bridge decks, concrete pavement, and concrete shoulders. Mechanical anchors may be ferrous or non-ferrous material. All anchors shall have a shear strength of 10,000 lb and an ultimate pullout strength of 6,500 lb.

[end of RSP 801-T-207]

Non-ferrous mechanical anchors shall be installed such that the top end of the sleeve is a minimum of 2 1/2 in. below the final finished concrete surface.

Ferrous mechanical anchors shall be completely removed when no longer required. All damage to the pavement shall be repaired as directed.

Non-ferrous anchor sleeves and the chemical adhesive component of chemical anchor systems may remain in place when no longer required. The holes remaining in the pavement shall be filled with appropriate material as directed.

(d) Delineation

~~Type 1 Temporary traffic~~ barriers used to separate two-way traffic shall be delineated with top mounted temporary barrier delineators and with side mounted delineators. The top mounted delineators shall be two-sided, shall be yellow, and shall be placed on every other section of barrier wall. The top mounted delineators shall be mounted perpendicular to the direction of traffic flow. The side mounted delineators shall be yellow and shall be mounted in accordance with 602.03(f).

REVISION TO STANDARD SPECIFICATIONS AND STANDARD DRAWINGS

SECTION 108 – PROSECUTION AND PROGRESS

108.04 Prosecution of the Work

SECTION 801 – TRAFFIC CONTROLS FOR CONSTRUCTION AND MAINTENANCE OPERATIONS

801.03 General Requirements

801.10 Temporary Traffic Barriers

801.10.1 Construction Zone Energy Absorbing Terminal, CZ

Temporary traffic barriers in locations other than separating two-way traffic shall be delineated with either Type C construction warning lights or top mounted temporary barrier delineators and with side mounted barrier delineators. The Type C lights or the top mounted barrier delineators shall be spaced at the number of feet equal to the number of miles per hour in the ~~posted~~ *regulatory* speed limit with a minimum spacing of 20 ft. Bi-directional lenses will be required on the warning lights when the barrier is adjacent to a lane that is carrying alternating one-way traffic. The color of the barrier delineators shall be white when located on the right side of the traffic lane, and yellow when located on the left side of the traffic lane. The color of the barrier delineators shall be white when located adjacent to a lane that is carrying alternating one-way traffic.

Where the temporary traffic barrier is located along a tapered alignment and is located behind drums or other reflective delineation devices, the Type C construction warning lights and barrier delineators shall not be used.

(e) End Treatment

Where possible, the ends of temporary traffic barriers shall be ~~flared~~ in accordance with 801.10(a). Where conditions do not allow the temporary traffic barrier to be ~~flared~~ in accordance with 801.10(a), appropriate end treatments shall be ~~incorporated to protect vehicles from the ends of the barriers installed.~~ *All end treatments shall be installed parallel to traffic and the first segment of temporary traffic barrier immediately downstream shall be parallel to the end treatment.* The end treatments shall ~~have re-direct capability and shall meet the appropriate test level 2 or 3 NCHRP 350 crash test standards and be approved for use by the FHWA~~ *be in accordance with 801.10.1.*

(f) Storage

No barrier segments shall be stored on the right-of-way unless written permission is given by the Department. Requests for permission to store traffic barrier segments on the right-of-way will not be accepted until after the contract has been awarded.

801.10.1 Construction Zone Energy Absorbing Terminal, CZ

The construction zone energy absorbing terminal, CZ, shall ~~have passed NCHRP 350 level 3 crash test~~ *meet the test level 3 NCHRP 350 or MASH crash test criteria* for all Interstate and other construction sites having a ~~construction zone~~ *regulatory* speed limit ~~prior to construction~~ in excess of 45 mph. ~~and level 2~~ *The CZ shall meet test level 2* for non-Interstate construction sites having a *regulatory speed limit prior to construction zone speed limit* of 45 mph or less. ~~All energy absorbing terminal, CZ, shall have redirect capabilities and shall be approved by the FHWA.~~

All energy absorbing terminal, CZ, shall have redirect capabilities. A copy of the crash test report confirming the product is NCHRP 350 or MASH compliant for the test

REVISION TO STANDARD SPECIFICATIONS AND STANDARD DRAWINGS

SECTION 108 – PROSECUTION AND PROGRESS

108.04 Prosecution of the Work

SECTION 801 – TRAFFIC CONTROLS FOR CONSTRUCTION AND MAINTENANCE OPERATIONS

801.03 General Requirements

801.10 Temporary Traffic Barriers

801.10.1 Construction Zone Energy Absorbing Terminal, CZ

level specified, or a copy of the FHWA eligibility letter, shall be furnished to the Engineer prior to the installation of the unit.



FINAL DRAFT MINUTES

REVISION TO STANDARD SPECIFICATIONS AND STANDARD DRAWINGS

E 801-TCCB-01 TEMPORARY CONCRETE BARRIER INDEX SHEET (WITH MARKUPS)

MARK-UP Editorial change to index this sheet

INDEX	
SHEET NO.	SUBJECT
1	Temporary Concrete Barrier Index Sheet
2	Temporary Concrete Barrier Dimensions <i>and Flare Rates</i>
3	Temporary Concrete Barrier Details
4	Temporary Concrete Barrier Double Taper End Section
5	Anchored Temporary Concrete Barrier, Drop-In Anchor
6	Anchored Temporary Concrete Barrier, Ferrule Loop Insert

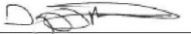
INDIANA DEPARTMENT OF TRANSPORTATION	
TEMPORARY CONCRETE BARRIER INDEX SHEET	
SEPTEMBER 2019	
STANDARD DRAWING NO. E 801-TCCB-01	
	 DESIGN STANDARDS ENGINEER
	5/2/2019 DATE
	 CHIEF ENGINEER
	6/5/2019 DATE

REVISION TO STANDARD SPECIFICATIONS AND STANDARD DRAWINGS

E 801-TCCB-02 TEMPORARY CONCRETE BARRIER DIMENSIONS (WITH REVISED MARKUPS)

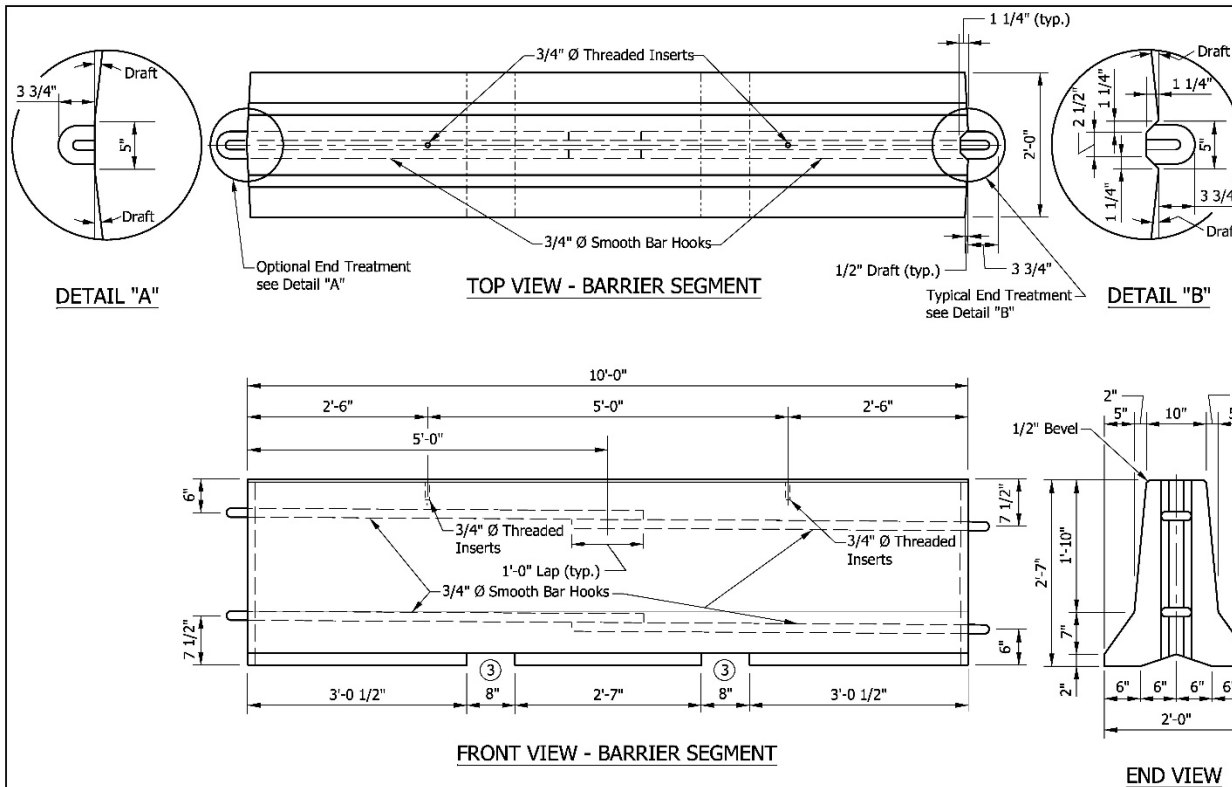

NOTES:

- For freeways and interstates, the maximum barrier flare rate and construction clear zone distance shall be based on 70 mph for the first run of barrier within the construction zone. For subsequent barrier placement, the barrier flare rates and construction clear zone distance shall be based on 70 mph unless otherwise shown on the plans. **The barrier taper flare rate**
- Maximum barrier taper rate flare** and construction clear zone distance ~~for construction zone speed~~ are shown in Table No. 1. Construction clear zone distance is measured from the through travel lane. **The barrier taper flare rate shall be as shown or flatter.**
- The dimensions of the lifting slots are subject to adjustment as necessary to accommodate handling equipment.
- For additional connection details see Standard Drawing E 801-TCCB-03.

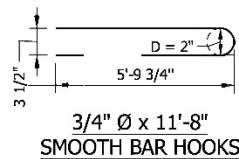

Construction Zone Design Speed	Maximum Barrier Taper Flare Rate	Construction Clear Zone Distance
70 mph	20:1	30
60 mph	18:1	30
55 mph	16:1	23
50 mph	14:1	16
45 mph	12:1	16
40 mph	10:1	13
≤ 35 mph	10:1	13

INDIANA DEPARTMENT OF TRANSPORTATION

TEMPORARY CONCRETE BARRIER DIMENSIONS AND FLARE RATES

SEPTEMBER 2024

STANDARD DRAWING NO. E 801-TCCB-02

DESIGN STANDARDS ENGINEER DATE

CHIEF ENGINEER DATE

REVISION TO STANDARD SPECIFICATIONS AND STANDARD DRAWINGS

E 801-TCCB-03 TEMPORARY CONCRETE BARRIER DETAILS (WITH MARKUPS)

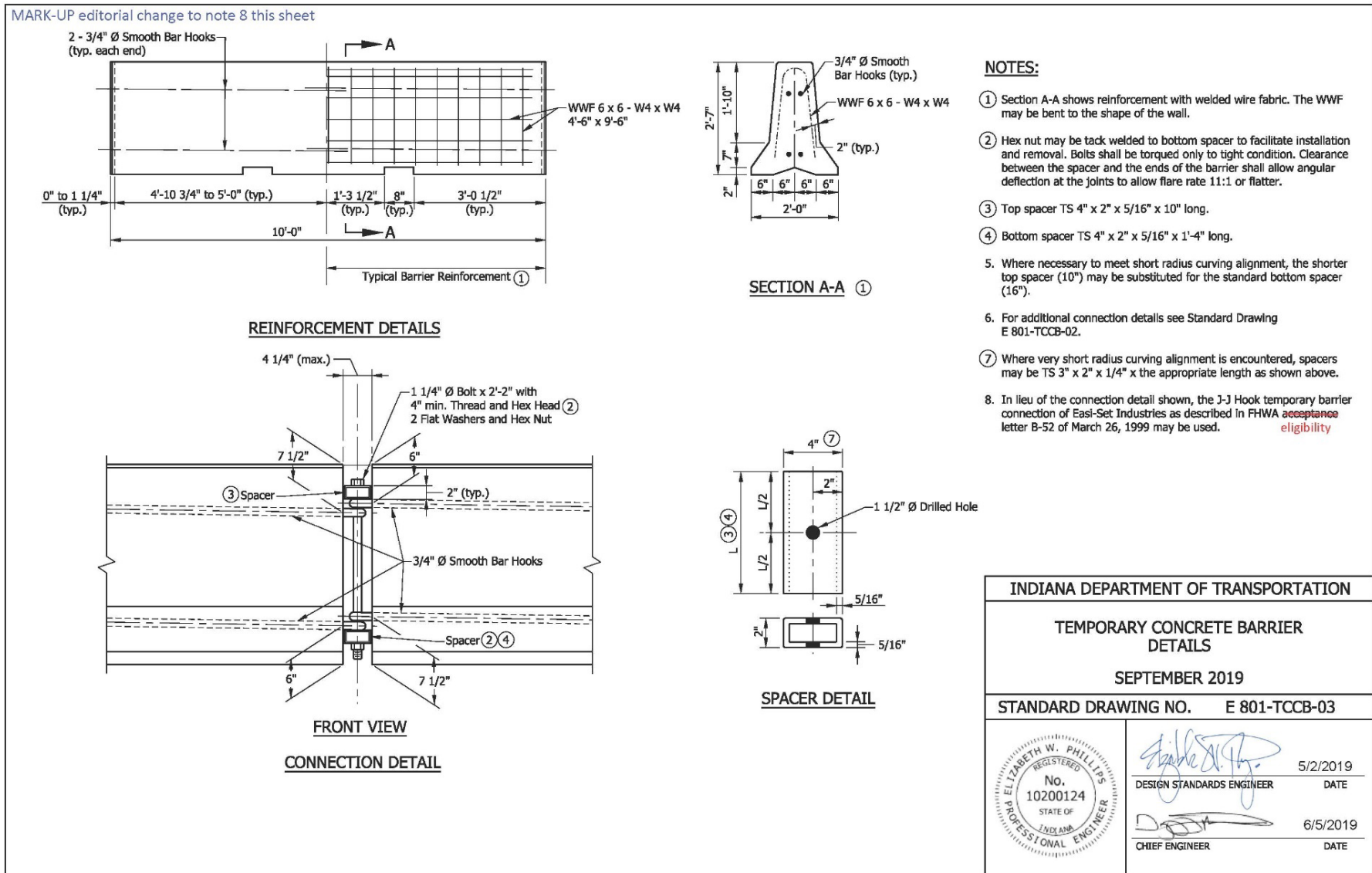

REVISION TO STANDARD SPECIFICATIONS AND STANDARD DRAWINGS

E 801-TCCB-04 TEMPORARY CONCRETE BARRIER DOUBLE TAPER END SECTION (NO CHANGES TO THIS SHEET)

MARK-UP no changes this sheet

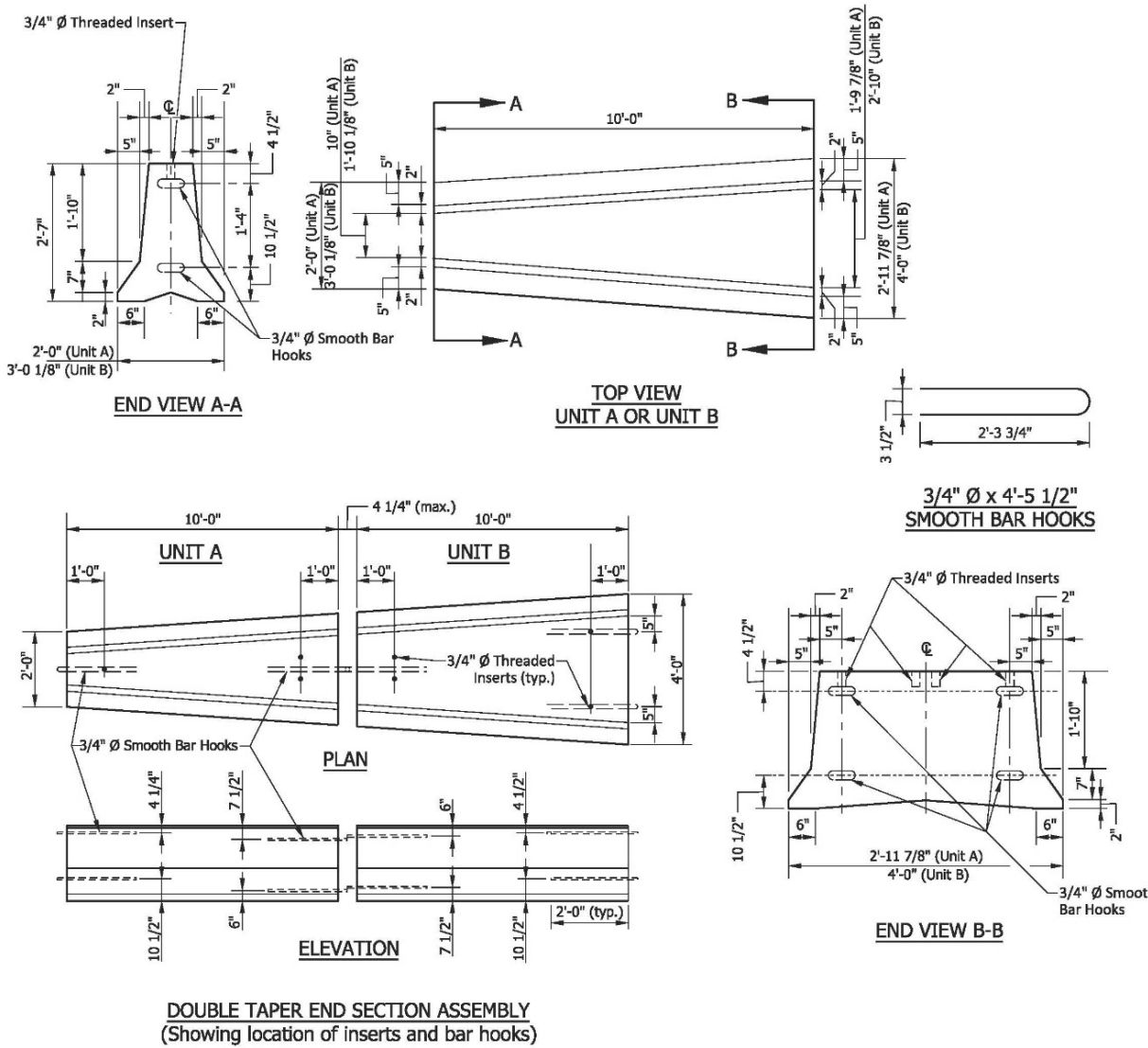

NOTES:

1. For connection details between Units A and B, see Standard Drawing E 801-TCCB-03.
2. Extreme ends of the double taper end section assembly require a 1 1/4" Ø bolt x 2'-3 1/2" (4" min. thread, hex head and hex nut) for connecting to adjacent temporary concrete barriers.

INDIANA DEPARTMENT OF TRANSPORTATION	
TEMPORARY CONCRETE BARRIER DOUBLE TAPER END SECTION	
SEPTEMBER 2019	
STANDARD DRAWING NO. E 801-TCCB-04	
	 DESIGN STANDARDS ENGINEER 5/2/2019 DATE
	 CHIEF ENGINEER 6/5/2019 DATE

REVISION TO STANDARD SPECIFICATIONS AND STANDARD DRAWINGS

E 801-TCCB-05 ANCHORED TEMPORARY CONCRETE BARRIER, DROP-IN ANCHOR (NO CHANGES TO THIS SHEET)

MARK-UP no changes this sheet

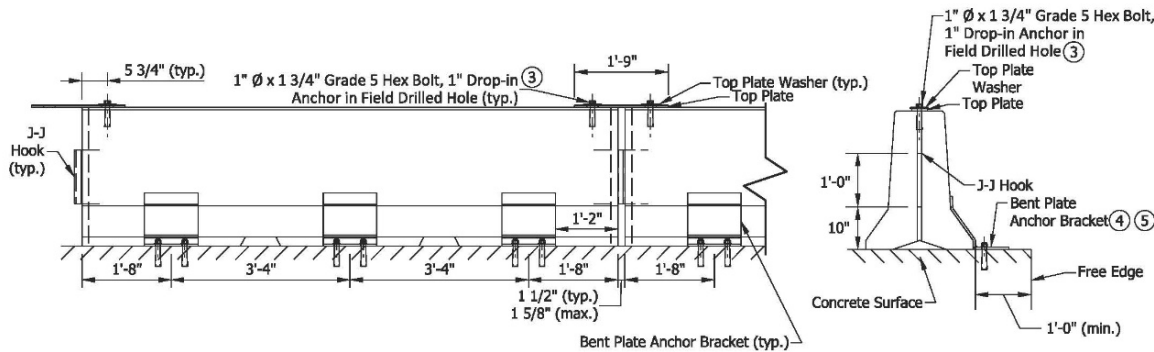

BARRIER FRONT VIEW

END VIEW

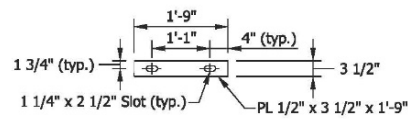

TOP PLATE DETAIL

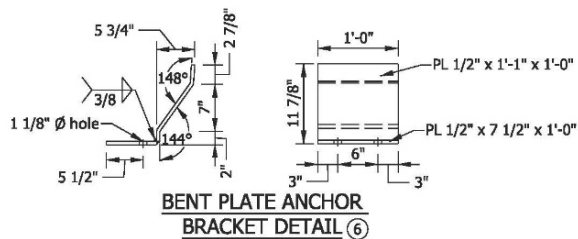

BENT PLATE ANCHOR BRACKET DETAIL 6

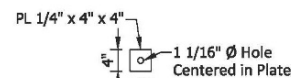

TOP PLATE WASHER DETAIL

NOTES:

1. All steel shall be ASTM A-36 hot rolled unless otherwise noted.
2. J-J Hooks are a product of Easi-Set Worldwide. Hooks shall be cast into the barrier in accordance with the manufacturer's recommendations.
3. The drop-in anchor and bolt shall be tightened to the anchor manufacturer's specifications. The anchor shall have a minimum ultimate shear capacity of 26.4 kips.
4. Bent plate anchor bracket shall be attached to a concrete surface using one of the following anchor systems. Minimum embedment shall be in accordance with the manufacturer's recommendations, but not less than 4 1/2 in.
 - 1-in. threaded rod, grade 55 minimum, with washer and nut. Rod shall be installed using an approved epoxy chemical anchor system with a minimum ultimate shear capacity of 21.2 kips; or
 - 1-in. diameter wedge anchor; or
 - 1-in. nominal diameter drop-in anchor with 1-in. diameter, grade 5 hex bolt.
5. When concrete will remain in place after anchoring is removed, the threaded rod anchoring system shall be used. The rod shall be completely removed, the hole shall be blown out to remove any moisture or debris, and the hole completely filled using the same epoxy that was used for anchoring the rod.
6. A single bent plate anchor bracket may be used instead of the two-plate detail as shown.

INDIANA DEPARTMENT OF TRANSPORTATION	
ANCHORED TEMPORARY CONCRETE BARRIER, DROP-IN ANCHOR SEPTEMBER 2019	
STANDARD DRAWING NO. E 801-TCCB-05	
	 5/29/2019 DESIGN STANDARDS ENGINEER DATE
 6/5/2019 CHIEF ENGINEER DATE	

REVISION TO STANDARD SPECIFICATIONS AND STANDARD DRAWINGS

E 801-TCCB-06 ANCHORED TEMPORARY CONCRETE BARRIER, FERRULE LOOP INSERT (NO CHANGES TO THIS SHEET)

MARK-UP - no changes this sheet

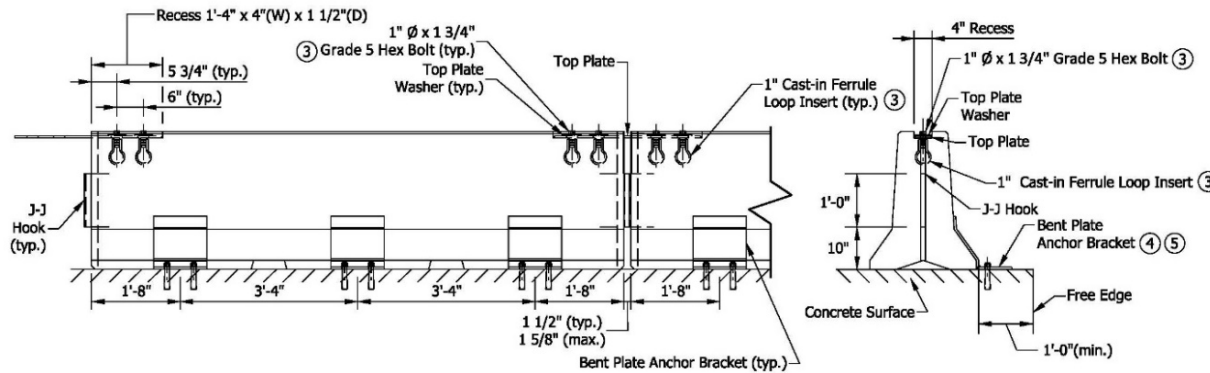

BARRIER FRONT VIEW

END VIEW

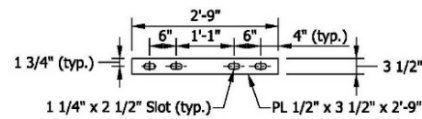

TOP PLATE DETAIL

NOTES:

1. All steel shall be ASTM A-36 hot rolled unless otherwise noted.
2. J-J Hooks are a product of Easi-Set Worldwide. Hooks shall be cast into the barrier in accordance with the manufacturer's recommendations.
3. The bolt shall be installed snug tight in the cast-in ferrule loop insert. The insert shall have a minimum ultimate shear capacity of 12.1 kips.
4. Bent plate anchor bracket shall be attached to a concrete surface using one of the following anchor systems. Minimum embedment shall be in accordance with the manufacturer's recommendations, but not less than 4 1/2 in.
 - 1-in. threaded rod, grade 55 minimum, with washer and nut. Rod shall be installed using an approved epoxy chemical anchor system with a minimum ultimate shear capacity of 21.2 kips; or
 - 1-in. diameter wedge anchor; or
 - 1-in. nominal diameter drop-in anchor with 1-in. diameter, grade 5 hex bolt.
5. When concrete will remain in place after anchoring is removed, the threaded rod anchoring system shall be used. The rod shall be completely removed, the hole shall be blown out to remove any moisture or debris, and the hole completely filled using the same epoxy that was used for anchoring the rod.
6. See E 801-TCCB-05 for bent plate anchor details, top plate washer details, and additional notes.

INDIANA DEPARTMENT OF TRANSPORTATION

ANCHORED TEMPORARY
 CONCRETE BARRIER,
 FERRULE LOOP INSERT
 SEPTEMBER 2019

STANDARD DRAWING NO. E 801-TCCB-06

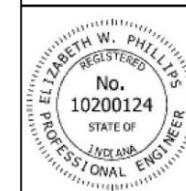



<i>Elizabeth W. Phillips</i>	5/29/2019
DESIGN STANDARDS ENGINEER	DATE
<i>John D. Novak</i>	6/5/2019
CHIEF ENGINEER	DATE

REVISION TO STANDARD SPECIFICATIONS AND STANDARD DRAWINGS

E 801-TCCB-01 TEMPORARY CONCRETE BARRIER INDEX SHEET (PROPOSED DRAFT)

INDEX	
SHEET NO.	SUBJECT
1	Temporary Concrete Barrier Index Sheet
2	Temporary Concrete Barrier Dimensions and Flare Rates
3	Temporary Concrete Barrier Details
4	Temporary Concrete Barrier Double Taper End Section
5	Anchored Temporary Concrete Barrier, Drop-In Anchor
6	Anchored Temporary Concrete Barrier, Ferrule Loop Insert

INDIANA DEPARTMENT OF TRANSPORTATION	
TEMPORARY CONCRETE BARRIER INDEX SHEET	
SEPTEMBER 2019	
STANDARD DRAWING NO. E 801-TCCB-01	
	 DESIGN STANDARDS ENGINEER
	5/2/2019 DATE
	 CHIEF ENGINEER
	6/5/2019 DATE

REVISION TO STANDARD SPECIFICATIONS AND STANDARD DRAWINGS

E 801-TCCB-02 TEMPORARY CONCRETE BARRIER DIMENSIONS AND FLARE RATES (PROPOSED REVISED DRAFT)

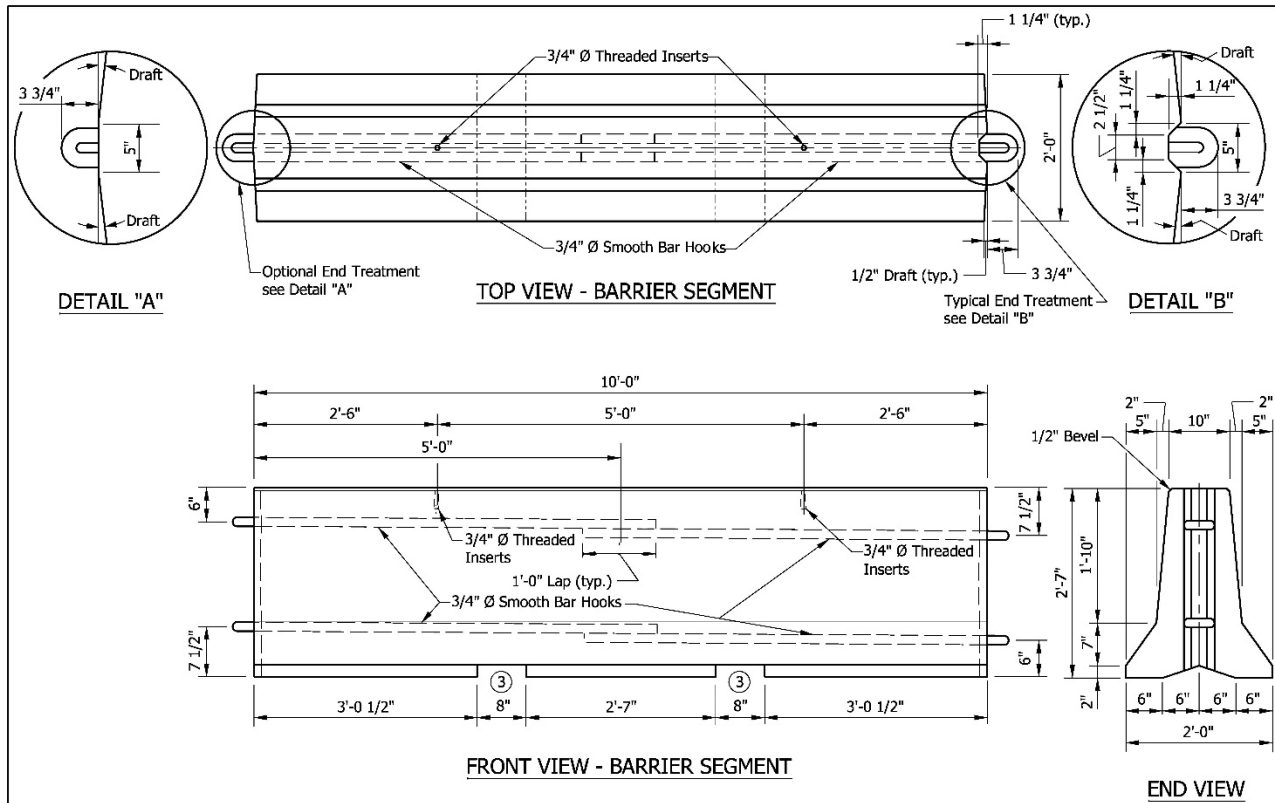

NOTES:

- 1 For freeways and interstates, the maximum barrier flare rate and construction clear zone distance shall be based on 70 mph for the first run of barrier within the construction zone. For subsequent barrier placement, the barrier flare rates and construction clear zone distance shall be based on 70 mph unless otherwise shown on the plans.
- 2 The barrier taper flare rate and construction clear zone distance are shown in Table No. 1. Construction clear zone distance is measured from the through travel lane. The barrier taper flare rate shall be as shown or flatter
- 3 The dimensions of the lifting slots are subject to adjustment as necessary to accommodate handling equipment.
- 4 For additional connection details see Standard Drawing E 801-TCCB-03.

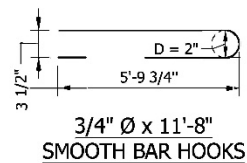

Construction Zone Design Speed	Barrier Taper Flare Rate	Construction Clear Zone Distance
70 mph	20:1	30
60 mph	18:1	30
55 mph	16:1	23
50 mph	14:1	16
45 mph	12:1	16
40 mph	10:1	13
≤ 35 mph	10:1	13

INDIANA DEPARTMENT OF TRANSPORTATION	
TEMPORARY CONCRETE BARRIER DIMENSIONS AND FLARE RATES	
SEPTEMBER 2024	
STANDARD DRAWING NO.	E 801-TCCB-02
DESIGN STANDARDS ENGINEER	DATE
CHIEF ENGINEER	DATE

REVISION TO STANDARD SPECIFICATIONS AND STANDARD DRAWINGS

E 801-TCCB-03 TEMPORARY CONCRETE BARRIER DETAILS (EDITORIAL CHANGE)

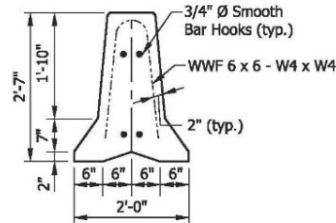
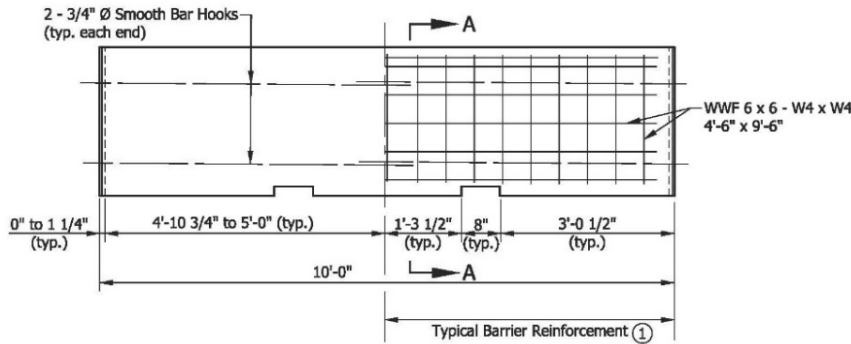

SECTION A-A ①

REINFORCEMENT DETAILS

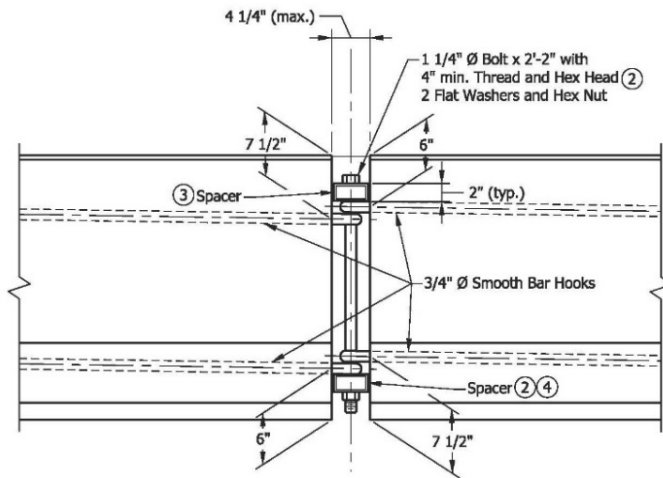

FRONT VIEW
 CONNECTION DETAIL

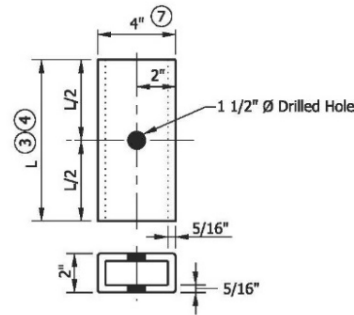

SPACER DETAIL

NOTES:

- ① Section A-A shows reinforcement with welded wire fabric. The WWF may be bent to the shape of the wall.
- ② Hex nut may be tack welded to bottom spacer to facilitate installation and removal. Bolts shall be torqued only to tight condition. Clearance between the spacer and the ends of the barrier shall allow angular deflection at the joints to allow flare rate 11:1 or flatter.
- ③ Top spacer TS 4" x 2" x 5/16" x 10" long.
- ④ Bottom spacer TS 4" x 2" x 5/16" x 1'-4" long.
5. Where necessary to meet short radius curving alignment, the shorter top spacer (10") may be substituted for the standard bottom spacer (16").
6. For additional connection details see Standard Drawing E 801-TCCB-02.
- ⑦ Where very short radius curving alignment is encountered, spacers may be TS 3" x 2" x 1/4" x the appropriate length as shown above.
8. In lieu of the connection detail shown, the J-J Hook temporary barrier connection of Easi-Set Industries as described in FHWA eligibility letter B-52 of March 26, 1999 may be used.

INDIANA DEPARTMENT OF TRANSPORTATION

TEMPORARY CONCRETE BARRIER
 DETAILS

SEPTEMBER 2019

STANDARD DRAWING NO. E 801-TCCB-03



	5/2/2019
DESIGN STANDARDS ENGINEER	DATE
	6/5/2019
CHIEF ENGINEER	DATE

REVISION TO STANDARD SPECIFICATIONS AND STANDARD DRAWINGS

E 801-TCCB-04 TEMPORARY CONCRETE BARRIER DOUBLE TAPER END SECTION (NO CHANGES)

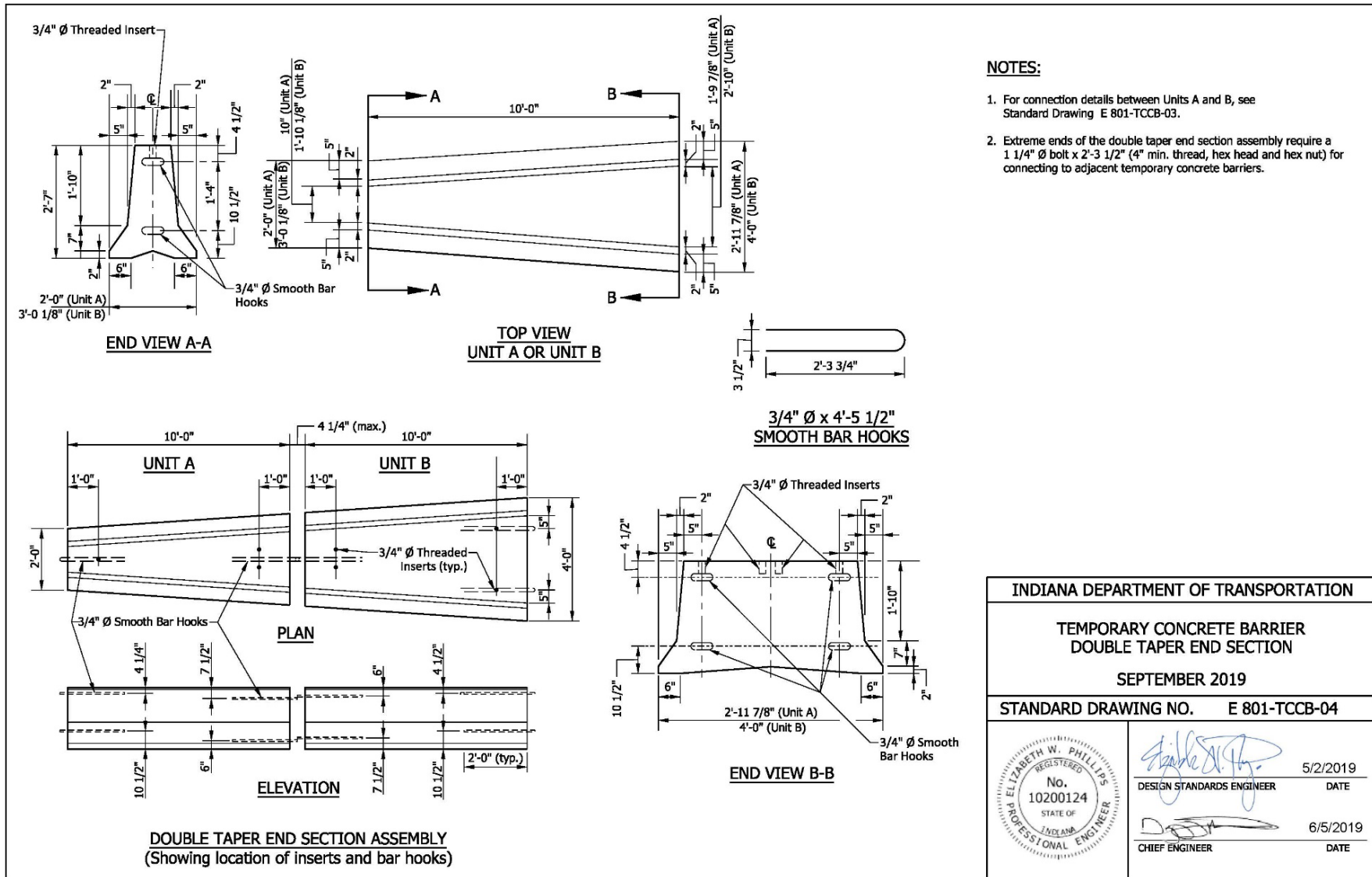

REVISION TO STANDARD SPECIFICATIONS AND STANDARD DRAWINGS

E 801-TCCB-05 ANCHORED TEMPORARY CONCRETE BARRIER, DROP-IN ANCHOR (NO CHANGES)

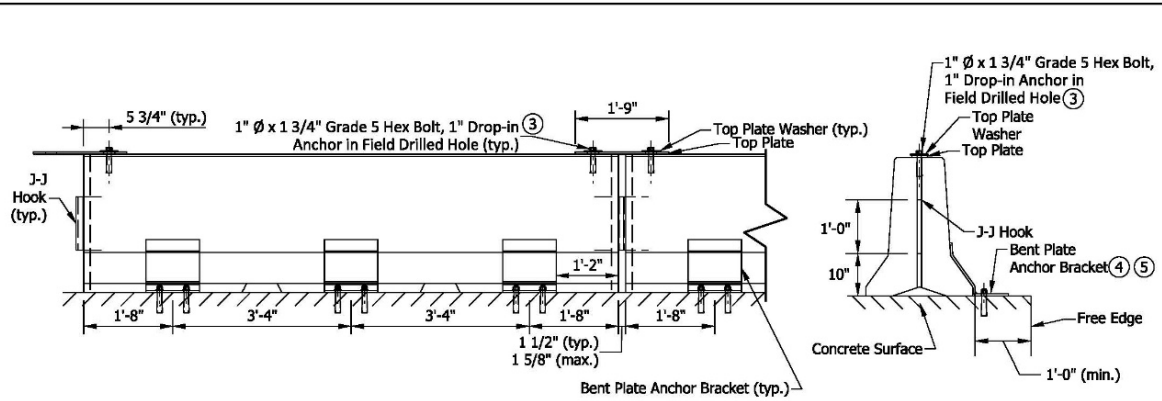

BARRIER FRONT VIEW

END VIEW

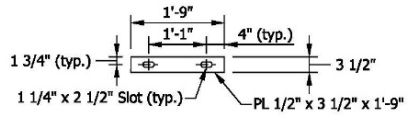

TOP PLATE DETAIL

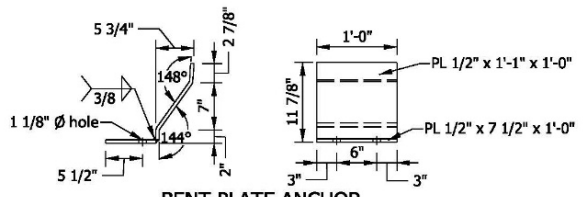

BENT PLATE ANCHOR BRACKET DETAIL

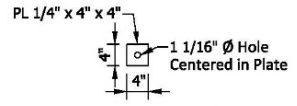

TOP PLATE WASHER DETAIL

NOTES:

1. All steel shall be ASTM A-36 hot rolled unless otherwise noted.
2. J-J Hooks are a product of Easi-Set Worldwide. Hooks shall be cast into the barrier in accordance with the manufacturer's recommendations.
3. The drop-in anchor and bolt shall be tightened to the anchor manufacturer's specifications. The anchor shall have a minimum ultimate shear capacity of 26.4 kips.
4. Bent plate anchor bracket shall be attached to a concrete surface using one of the following anchor systems. Minimum embedment shall be in accordance with the manufacturer's recommendations, but not less than 4 1/2 in.
 - 1-in. threaded rod, grade 55 minimum, with washer and nut. Rod shall be installed using an approved epoxy chemical anchor system with a minimum ultimate shear capacity of 21.2 kips; or
 - 1-in. diameter wedge anchor; or
 - 1-in. nominal diameter drop-in anchor with 1-in. diameter, grade 5 hex bolt.
5. When concrete will remain in place after anchoring is removed, the threaded rod anchoring system shall be used. The rod shall be completely removed, the hole shall be blown out to remove any moisture or debris, and the hole completely filled using the same epoxy that was used for anchoring the rod.
6. A single bent plate anchor bracket may be used instead of the two-plate detail as shown.

INDIANA DEPARTMENT OF TRANSPORTATION	
ANCHORED TEMPORARY CONCRETE BARRIER, DROP-IN ANCHOR	
SEPTEMBER 2019	
STANDARD DRAWING NO. E 801-TCCB-05	
	 5/29/2019 DESIGN STANDARDS ENGINEER DATE
	 6/5/2019 CHIEF ENGINEER DATE

REVISION TO STANDARD SPECIFICATIONS AND STANDARD DRAWINGS

E 801-TCCB-06 ANCHORED TEMPORARY CONCRETE BARRIER, FERRULE LOOP INSERT (NO CHANGES)

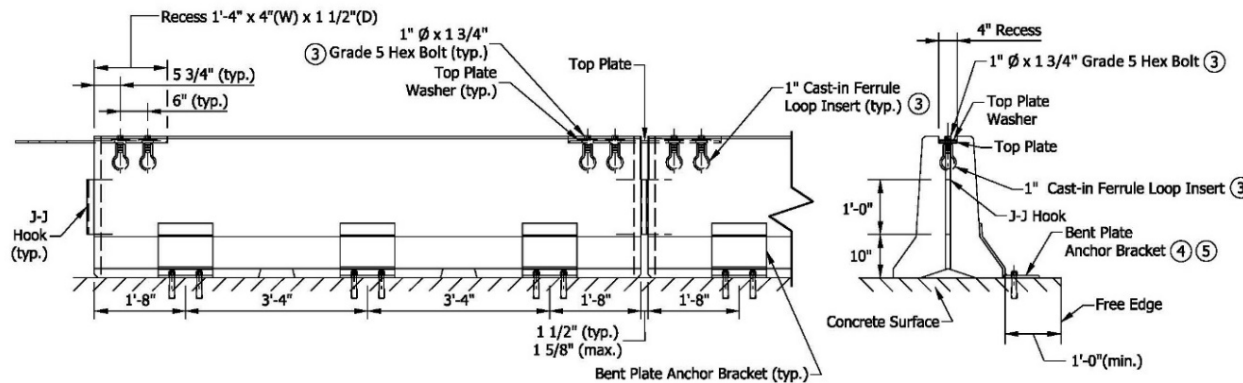

BARRIER FRONT VIEW

END VIEW

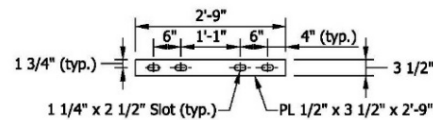

TOP PLATE DETAIL

NOTES:

1. All steel shall be ASTM A-36 hot rolled unless otherwise noted.
2. J-J Hooks are a product of Easi-Set Worldwide. Hooks shall be cast into the barrier in accordance with the manufacturer's recommendations.
3. The bolt shall be installed snug tight in the cast-in ferrule loop insert. The insert shall have a minimum ultimate shear capacity of 12.1 kips.
4. Bent plate anchor bracket shall be attached to a concrete surface using one of the following anchor systems. Minimum embedment shall be in accordance with the manufacturer's recommendations, but not less than 4 1/2 in.
 - 1-in. threaded rod, grade 55 minimum, with washer and nut. Rod shall be installed using an approved epoxy chemical anchor system with a minimum ultimate shear capacity of 21.2 kips; or
 - 1-in. diameter wedge anchor; or
 - 1-in. nominal diameter drop-in anchor with 1-in. diameter, grade 5 hex bolt.
5. When concrete will remain in place after anchoring is removed, the threaded rod anchoring system shall be used. The rod shall be completely removed, the hole shall be blown out to remove any moisture or debris, and the hole completely filled using the same epoxy that was used for anchoring the rod.
6. See E 801-TCCB-05 for bent plate anchor details, top plate washer details, and additional notes.

INDIANA DEPARTMENT OF TRANSPORTATION	
ANCHORED TEMPORARY CONCRETE BARRIER, FERRULE LOOP INSERT SEPTEMBER 2019	
STANDARD DRAWING NO.	E 801-TCCB-06
	<p style="text-align: right;">5/29/2019 DATE</p> <p style="text-align: right;">8/5/2019 DATE</p>
<p style="text-align: center;">No. 10200124 STATE OF INDIANA PROFESSIONAL ENGINEER</p>	<p style="text-align: right;">DESIGN STANDARDS ENGINEER</p> <p style="text-align: right;">CHIEF ENGINEER</p>

REVISION TO STANDARD SPECIFICATIONS AND STANDARD DRAWINGS

Drawings for General Instructions to Field Employees (GIFE) (proposed at the meeting, see DISCUSSION)

1. TTB Flared with End Outside Construction Clear Zone

Where the end of the TTB exposed to approaching traffic is flared and the offset is **equal to or greater than the construction clear zone distance** from the travel lane, a CZ is not required.

To place TTB in the configuration shown, the conditions below must be satisfied. **If any condition is not met, barrier should be placed parallel to traffic and a CZ placed on the approaching end.**

- (Freeway/Interstate) Side slope on approach and under barrier must be 10:1 or flatter. Other roadways 4:1 max**
- Barrier flare rate must be equal to or flatter than required based on Construction Zone Speed**

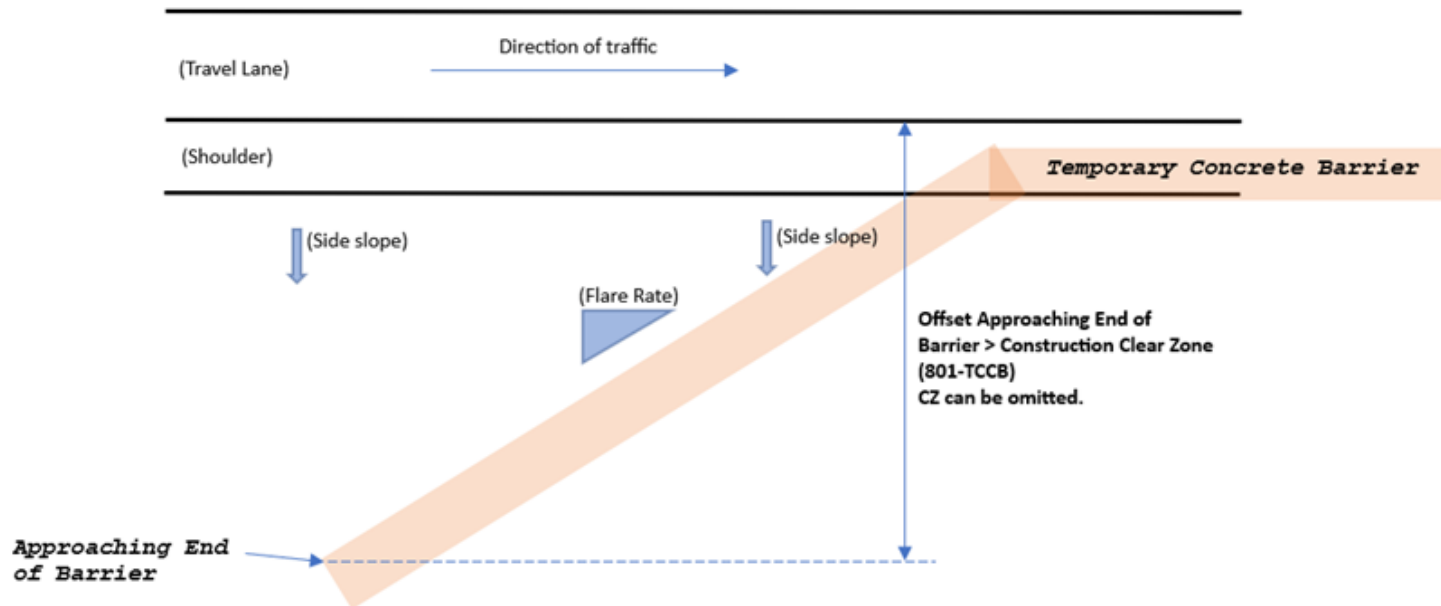

REVISION TO STANDARD SPECIFICATIONS AND STANDARD DRAWINGS

Drawings for General Instructions to Field Employees (GIFE) (proposed at the meeting, see DISCUSSION)

2. TTB Parallel to Traffic with CZ

Where the TTB end is exposed to approaching traffic and the offset is less than the construction clear zone distance from the travel lane, a CZ must be placed on the approaching end.

Where guardrail or concrete barrier is adjacent TTB, the following condition must be satisfied.

- Approach end of TTB must overlap guardrail or concrete barrier by required distance shown.

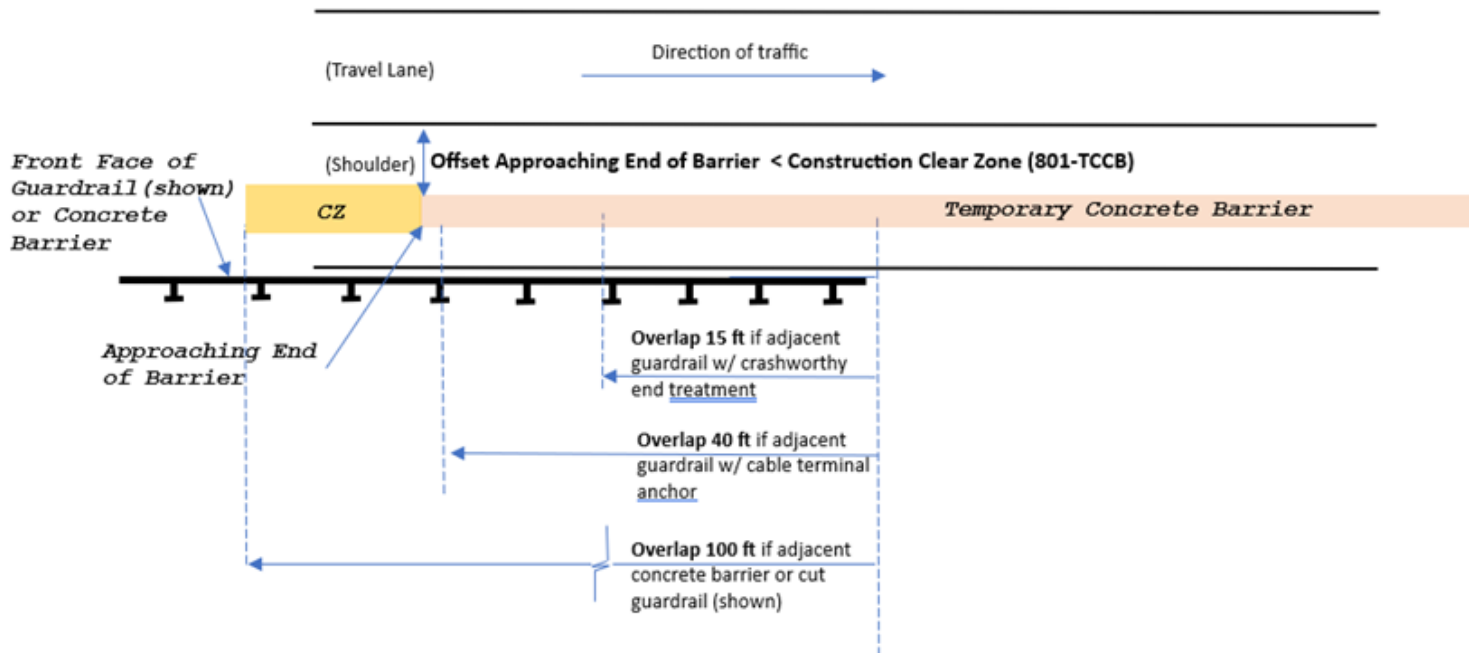

REVISION TO STANDARD SPECIFICATIONS AND STANDARD DRAWINGS

Drawings for General Instructions to Field Employees (GIFE) (proposed at the meeting, see DISCUSSION)

3. TTB Behind Guardrail

Where the TTB end is exposed to approaching traffic and the offset is **less than the construction clear zone distance** from the travel lane, the barrier may be flared behind existing guardrail and CZ omitted.

To place TTB in the configuration shown, the following conditions must be satisfied. **If any condition is not met, barrier should be placed parallel to traffic and a CZ placed on the approaching end.**

- [Freeway/Interstate] Side slope on approach and under barrier must be 10:1 or flatter. Other roadways 4:1 max.**
- Barrier flare rate must be equal to or flatter than the required flare rate based on Construction Zone Speed**
- Approach end of barrier must overlap guardrail by required distance based on type of end treatment.**

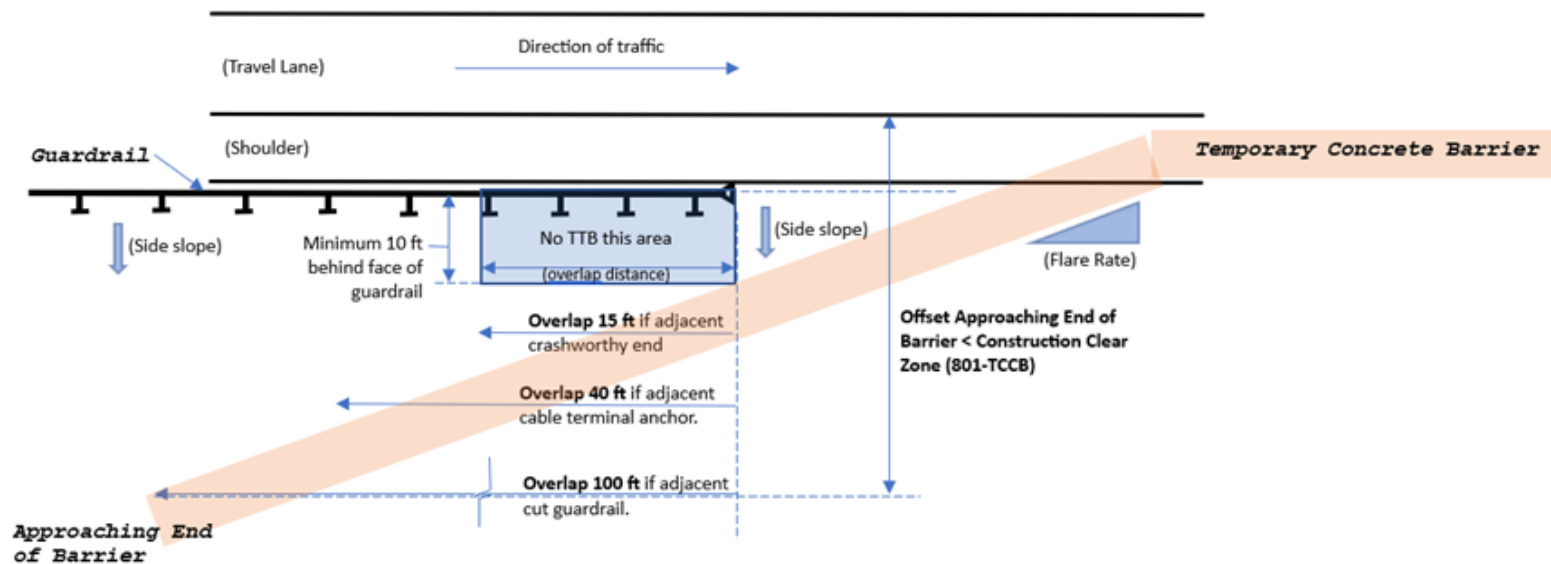

COMMENTS AND ACTION

108.04 Prosecution of the Work

801.03 General Requirements
 801.10 Temporary Traffic Barriers
 801.10.1 Construction Zone Energy Absorbing Terminal, CZ
 E 801-TCCB Series

DISCUSSION:

This item was introduced and presented by Mr. Novak, assisted by Ms. Smutzer, who explained that 801.10 has allowed modifications to terminating temporary traffic barrier when field conditions do not allow placement as shown on the construction plans. These modifications to flare rates or termination points without CZ units are being made in the field, many times without approval by the designer. These types of safety modifications should be conservative or reviewed and approved by the designer. Spec section 801.03 describes the devices that are to be inspected by the CWTS, which currently excludes the temporary traffic barrier.

Mr. Novak proposed to delete the existing language in 801.10 that allows extreme modification of the flare rate and offset of the termination point of temporary traffic barrier and add in more descriptive termination allowances.

Ms. Smutzer explained revisions made prior to the meeting.

Proposed revisions for RSP 801-T-207 and Standard Drawing series 801-TCCB are as described in the proposal sheet and shown above. Ms. Mouser shared additional intended revisions to the drawings and GIFE changes.

There was no further discussion and this item passed as revised.

	<u>Action:</u>
Motion: Mr. Novak Second: Mr. Koch Ayes: 10 Nays: 0 FHWA Approval: YES	<input type="checkbox"/> Passed as Submitted <input checked="" type="checkbox"/> Passed as Revised <input type="checkbox"/> Withdrawn
2024 Standard Specifications Sections referenced and/or affected: 801 begin pg. 867.	<input checked="" type="checkbox"/> 2026 Standard Specifications <input type="checkbox"/> Revise Pay Items List <input type="checkbox"/> Notification to Designers if change is <u>not</u> addressed by RSP
Recurring Special Provisions or Plan Details: 801-T-207 TEMPORARY TRAFFIC BARRIERS	<input type="checkbox"/> Create RSP (No. __) <input type="checkbox"/> Effective:
Standard Drawing affected: 801-TCCB Series	<input checked="" type="checkbox"/> Revise RSP (No. 801-T-207) <input type="checkbox"/> Effective: December 1, 2023
Design Manual Sections affected: 503-3.05(04) and (05)	<input checked="" type="checkbox"/> Standard Drawing 801-TCCB Series <input type="checkbox"/> Effective: September 1, 2024
GIFE Sections cross-references: 2.8, 21.2	<input checked="" type="checkbox"/> Create RPD (No. 801-T-207d) <input type="checkbox"/> Effective: December 1, 2023
	<input checked="" type="checkbox"/> GIFE Update <input checked="" type="checkbox"/> Frequency Manual Update <input type="checkbox"/> SiteManager Update

PROPOSAL TO STANDARDS COMMITTEE

PROBLEM(S) ENCOUNTERED: Lack of competition driving MSE Walls cost as only 1 vendor on existing QPL

PROPOSED SOLUTION: Allow 60 grade steel for MSE Wall ground reinforcement to allow approval of additional Wall vendors/systems.

APPLICABLE STANDARD SPECIFICATIONS: 735 and 910

APPLICABLE STANDARD DRAWINGS: None

APPLICABLE DESIGN MANUAL SECTION: None

APPLICABLE SECTION OF GIFE: None

APPLICABLE RECURRING SPECIAL PROVISIONS: None

PAY ITEMS AFFECTED: None

APPLICABLE SUB-COMMITTEE ENDORSEMENT: Wall Committee

IF APPROVED AS RECURRING SPECIAL PROVISION OR PLAN DETAILS, PROPOSED BASIS FOR USE:
N/A

IMPACT ANALYSIS (attach report): Yes

Submitted By: Jim Reilman

Title: State Materials Engineer

Organization: INDOT

Phone Number: (317) 522-9692

Date: 06/19/2023

IMPACT ANALYSIS REPORT CHECKLIST

Explain the business case as to why this item should be presented to the Standards Committee for approval. Answer the following questions with Yes, No or N/A.

Does this item appear in any other specification sections? No

Will approval of this item affect the Approved Materials List? No

Will this proposal improve:

Construction costs? No

Construction time? No

Customer satisfaction? No

Congestion/travel time? No

Ride quality? No

Will this proposal reduce operational costs or maintenance effort? No

Will this item improve safety:

For motorists? No

For construction workers? No

Will this proposal improve quality for:

Construction procedures/processes? No

Asset preservation? No

Design process? No

Will this change provide the contractor more flexibility? Yes

Will this proposal provide clarification for the Contractor and field personnel? No

Can this item improve/reduce the number of potential change orders? No

Is this proposal needed for compliance with:

Federal or State regulations? No

AASHTO or other design code? No

Is this item editorial? No

Provide any further information as to why this proposal should be placed on the Standards Committee meeting Agenda: N/A

REVISION TO STANDARD SPECIFICATIONS

SECTION 735 – TEMPORARY WIRE-FACED MECHANICALLY STABILIZED EARTH RETAINING WALLS

735.03 Design Criteria

SECTION 910 – METAL MATERIALS

910.07 Steel Components of MSE Retaining Walls

(Note: Proposed changes shown highlighted gray)

The Standard Specifications are revised as follows:

SECTION 735, BEGIN LINE 30, DELETE AND INSERT AS FOLLOWS:

735.03 Design Criteria

The design life of the wall shall be 36 months. The minimum allowable yield stress for reinforcement shall be ~~65~~60 ksi. The maximum allowable stress in the reduced section after sacrificial steel has been removed at the end of the design life shall be $0.55F_y$ for WWR. The maximum allowable stress may be increased to $0.77F_y$ if the design life does not exceed 36 months. The reduced section of ground reinforcement shall be limited to the allowable stress shown above at the end of the 36-month design life.

The connections of the ground-reinforcing steel to the wire-facing shall not be more than 24 in. apart vertically.

The design shall otherwise be in accordance with 731.02 and 731.03.

SECTION 910, BEGIN LINE 493, INSERT AS FOLLOWS:

(b) Ground Reinforcement

The ground reinforcement shall be either a deformed steel strip or a welded-wire grid. The grid or strip used shall be consistent with that used in the pullout test and shall be consistent throughout the project.

The grid shall consist of not less than two longitudinal wires, perpendicular to the wall, welded to equally spaced cross ribs capable of developing passive pressure with the fill. The deformed strip shall be of constant width. The strip thickness shall vary only from the undeformed section to the deformed section as required to produce the pullout resistance.

The face-panel edges shall be configured to conceal the joints. All horizontal and vertical joints shall be covered with a joint cover to prevent backfill leakage while passing water.

Ground-reinforcement units shall be hot rolled from bars to the required shape and dimensions. Physical and mechanical properties of the units shall be in accordance with ASTM A572, grade ~~60~~ or 65. Tie strips shall be shop fabricated with hot-rolled steel in accordance with the minimum requirements of ASTM A1011, grade 50. Galvanization for ground-reinforcing units and tie strips shall be in accordance with ASTM A123, coating grade 85, for strip-type reinforcements or ASTM A641, class 5 or class C, for bar mat or grid-type reinforcements.

COMMENTS AND ACTION

735.03 Design Criteria
 910.07 Steel Components of MSE Retaining Walls

DISCUSSION:

Mr. Reilman introduced and presented this item stating that lack of competition is driving MSE Walls costs, since there is only one vendor on the existing QPL.

Mr. Reilman proposed to allow 60 grade steel for MSE Wall ground reinforcement to allow approval of additional Wall vendors and systems.

Further clarification was provided by Mr. Turk.

There was no further discussion and this item passed as submitted.

	<u>Action:</u>
Motion: Mr. Reilman Second: Mr. Novak Ayes: 10 Nays: 0 FHWA Approval: YES	<input checked="" type="checkbox"/> Passed as Submitted <input type="checkbox"/> Passed as Revised <input type="checkbox"/> Withdrawn
2024 Standard Specifications Sections referenced and/or affected: 735.03 pg 859; 910.07 pg 1063	<input checked="" type="checkbox"/> 2026 Standard Specifications Revise Pay Items List Notification to Designers if change is <u>not</u> addressed by RSP
Recurring Special Provisions or Plan Details: NONE	<input checked="" type="checkbox"/> Create RSPs (No. 735-R-760 and 910-M-068) Effective: December 1, 2023
Standard Drawing affected: NONE	<input type="checkbox"/> Revise RSP (No. __) Effective:
Design Manual Sections affected: NONE	<input type="checkbox"/> Standard Drawing Effective:
GIFE Sections cross-references: NONE	<input type="checkbox"/> Create RPD (No. __) Effective: <input type="checkbox"/> GIFE Update <input type="checkbox"/> Frequency Manual Update <input type="checkbox"/> SiteManager Update

PROPOSAL TO STANDARDS COMMITTEE

PROBLEM(S) ENCOUNTERED: There is confusion internally and externally on B Borrow and the testing requirements depending on the source.

PROPOSED SOLUTION: Incorporate the proposed changes, intended to clarify testing requirements, reporting requirements, and who performs the testing.

APPLICABLE STANDARD SPECIFICATIONS: 211.02

APPLICABLE STANDARD DRAWINGS: none

APPLICABLE DESIGN MANUAL SECTION: none

APPLICABLE SECTION OF GIFE: maybe 3.17?

APPLICABLE RECURRING SPECIAL PROVISIONS: create 211 rsp

PAY ITEMS AFFECTED: none

APPLICABLE SUB-COMMITTEE ENDORSEMENT: Ad hoc: Nathan Butts, Missy Ehrhart, Dave Jacobs, Jim Reilman, Heather Woods

IF APPROVED AS RECURRING SPECIAL PROVISION OR PLAN DETAILS, PROPOSED BASIS FOR USE:
Required for all contracts with any 211 pay item

IMPACT ANALYSIS (attach report):

Submitted By: Jim Reilman

Title: State Materials Engineer

Organization: INDOT

Phone Number: (317) 522-9692

Date: 6/9/23

IMPACT ANALYSIS REPORT CHECKLIST

Explain the business case as to why this item should be presented to the Standards Committee for approval. Answer the following questions with Yes, No or N/A.

Does this item appear in any other specification sections? yes

Will approval of this item affect the Approved Materials List? No

Will this proposal improve:

Construction costs? Yes

Construction time? Yes

Customer satisfaction? N/A

Congestion/travel time? N/A

Ride quality? N/A

Will this proposal reduce operational costs or maintenance effort? N/A

Will this item improve safety:

For motorists? N/A

For construction workers? N/A

Will this proposal improve quality for:

Construction procedures/processes? yes

Asset preservation? yes

Design process? N/A

Will this change provide the contractor more flexibility? yes

Will this proposal provide clarification for the Contractor and field personnel? yes

Can this item improve/reduce the number of potential change orders? N/A

Is this proposal needed for compliance with:

Federal or State regulations? No

AASHTO or other design code? No

Is this item editorial? No

Provide any further information as to why this proposal should be placed on the Standards Committee meeting Agenda:

REVISION TO STANDARD SPECIFICATIONS

SECTION 211 – B BORROW AND STRUCTURE BACKFILL
211.02 Materials

(Note: Proposed changes shown highlighted gray)

The Standard Specifications are revised as follows:

SECTION 211, BEGIN LINE 11, DELETE AND INSERT AS FOLLOWS:

211.02 Materials

Materials shall be in accordance with the following:

B Borrow	904.06
Flowable Backfill	213
Geotextile	918.02
Structure Backfill	904.05

Aggregate for end bent backfill shall be No. 8 or No. 9 crushed stone or ACBF, class D or higher.

~~If the Contractor is directed to use material excavated from within the project limits as B borrow or as structure backfill, that material shall be used and gradation control will be performed by the Department, in accordance with AASHTO T 11 and T 27. Otherwise, the Contractor has the option of either providing B borrow or structure backfill from an established CAPP source, from the Department’s QPL of Certified Aggregate Producers or supplying the material from another a non-CAPP source. The Contractor has the following options for supplying B borrow or structure backfill from a local site B borrow or structure backfill from a non-CAPP source shall be in accordance with the following:~~

- (a) ~~the establishment of~~ Contractor may establish a CAPP Producer Yard at ~~the~~ local site in accordance with 917; or
- (b) use ~~a CAPP Certified Aggregate Technician or a consultant on the laboratory from the Department’s~~ list of Qualified Geotechnical Consultants for ~~Gradation Control Testing~~ control testing in accordance with AASHTO T 11, T 27, and T 267.

~~For material excavated within the project limits, gradation control testing will be performed by the Department if the Contractor is directed to use the material as B borrow or as structure backfill.~~

~~The frequency of gradation control testing shall be one test per 2,000 t based on production samples into a stockpile or by over the scales measurement, with a minimum of two tests per contract, one in the beginning and one near the mid point.~~

~~The sampling and testing of these materials shall be in accordance with applicable requirements of 904 for fine and coarse aggregates.~~

REVISION TO STANDARD SPECIFICATIONS

SECTION 211 – B BORROW AND STRUCTURE BACKFILL

211.02 Materials

~~The Contractor shall notify the Engineer in writing of the plan to measure the material.~~

1. *The testing location and equipment will be subject to inspection by the Department.*
2. *The frequency of control testing for AASHTO T 11 and T 27 shall be one test per 2,000 t based on production samples into a stockpile or by over the scales measurement, with a minimum of two tests per contract, one in the beginning and one near the mid-point. The frequency of control testing for AASHTO T 267 shall be one test per contract. The sampling and testing of these materials shall be in accordance with applicable requirements of 904 for fine and coarse aggregates. The Contractor shall notify the Engineer in writing of the plan to measure the material.*
3. *A type A certification in accordance with 916 shall be provided for each control test. The following information shall be shown on each certification:*
 - a. *the control tests performed,*
 - b. *the results from the control tests,*
 - c. *the applicable requirements for the control test,*
 - d. *the name of the consultant laboratory from the Qualified Department's list of Qualified Geotechnical Consultants where the test was performed.*

CONSTRUCTION REQUIREMENTS

COMMENTS AND ACTION

211.02 Materials

DISCUSSION:

This item was introduced and presented by Mr. Reilman who stated that there is confusion internally and externally on B Borrow and the testing requirements, depending on the source.

Mr. Reilman proposed to incorporate the proposed changes, which are intended to clarify testing requirements, reporting requirements, and who performs the testing.

Mr. Reilman withdrew this item pending further review and revisions.

	<u>Action:</u>
Motion: Second: Ayes: Nays: FHWA Approval:	<input type="checkbox"/> Passed as Submitted <input type="checkbox"/> Passed as Revised <input checked="" type="checkbox"/> Withdrawn
2024 Standard Specifications Sections referenced and/or affected: 211.02 pg. 232.	<input type="checkbox"/> 2026 Standard Specifications <input type="checkbox"/> Revise Pay Items List <input type="checkbox"/> Notification to Designers if change is <u>not</u> addressed by RSP
Recurring Special Provisions or Plan Details: NONE	<input type="checkbox"/> Create RSP (No. __) Effective:
Standard Drawing affected: NONE	<input type="checkbox"/> Revise RSP (No. __) Effective:
Design Manual Sections affected: NONE	<input type="checkbox"/> Standard Drawing Effective:
GIFE Sections cross-references: 3.17 (TBD)	<input type="checkbox"/> Create RPD (No. __) Effective:
	<input type="checkbox"/> GIFE Update <input type="checkbox"/> Frequency Manual Update <input type="checkbox"/> SiteManager Update

PROPOSAL TO STANDARDS COMMITTEE

PROBLEM(S) ENCOUNTERED: The current detail for Type I-A joints includes a backer rod to limit the depth of silicone sealant to the upper ½ in. of the joint, leaving the remaining depth open. Research has shown that this creates a space for moisture to enter once the sealant breaks down, causing the space below the sealant to experience more rapid deterioration of the concrete.

PROPOSED SOLUTION: Similar to the current joint details for concrete pavement shown in Standard Drawing series E 503-CCPJ, the backer rod will be eliminated and the saw cut joint will be completely filled with either silicone or hot poured sealant. The Type I-A joint will also be revised to a single saw cut rather than the current two phase cut to facilitate the complete filling of the joint and simplify construction.

APPLICABLE STANDARD SPECIFICATIONS: 609

APPLICABLE STANDARD DRAWINGS: E 609-BRJT

APPLICABLE DESIGN MANUAL SECTION: Various figures in Chapter 409 show the location of Type I-A joints, but none contain enough detail to require a revision.

APPLICABLE SECTION OF GIFE: N/A

APPLICABLE RECURRING SPECIAL PROVISIONS: 609-B-311 will need to be updated to reflect the proposed changes to the Joint Materials. No other changes anticipated. These need to remain separate RSPs, since the basis for use will be different.

PAY ITEMS AFFECTED: N/A

APPLICABLE SUB-COMMITTEE ENDORSEMENT: Coordination with Mike Nelson.

IF APPROVED AS RECURRING SPECIAL PROVISION OR PLAN DETAILS, PROPOSED BASIS FOR USE:
All contracts that include 609 pay items.

IMPACT ANALYSIS (attach report):

Submitted By: Pete White
Title: Design Manager
Division: INDOT Bridge Engineering
E-mail: pewwhite@indot.in.gov
Date: May 31, 2023

IMPACT ANALYSIS REPORT CHECKLIST

Explain the business case as to why this item should be presented to the Standards Committee for approval. Answer the following questions with Yes, No or N/A.

Does this item appear in any other specification sections? No

Will approval of this item affect the Qualified Products List (QPL)? No

Will this proposal improve:

Construction costs? Yes

Construction time? Yes

Customer satisfaction? No

Congestion/travel time? No

Ride quality? No

Will this proposal reduce operational costs or maintenance effort? Yes

Will this item improve safety:

For motorists? No

For construction workers? No

Will this proposal improve quality for:

Construction procedures/processes? Yes

Asset preservation? Yes

Design process? No

Will this change provide the contractor more flexibility? Yes

Will this proposal provide clarification for the Contractor and field personnel? No

Can this item improve/reduce the number of potential change orders? No

Is this proposal needed for compliance with:

Federal or State regulations? No

AASHTO or other design code? No

Is this item editorial? No

Provide any further information as to why this proposal should be placed on the Standards Committee meeting Agenda: This change should increase the service life of Type I-A joints.

REVISION TO STANDARD SPECIFICATIONS AND STANDARD DRAWINGS

SECTION 609 – REINFORCED CONCRETE BRIDGE APPROACHES
609.02 Materials
E 609-BRJT-01 TYPE I-A JOINT

(Note: Proposed changes shown highlighted gray)

The Standard Specifications are revised as follows:

SECTION 609, BEGIN LINE 10, DELETE AND INSERT AS FOLLOWS:

609.02 Materials

Materials shall be in accordance with the following:

Coarse Aggregate, Class B or Higher, Size No. 8	904.03
Coarse Aggregate, Class D or Higher, Size No. 53	904.03
Concrete, Class A.....	702
Curing Materials.....	912.01
Geotextile for Pavement and Subgrade.....	918.02
Hot Poured Joint Sealant.....	906.02(a)2
Joint Materials Silicone Joint Sealants.....	906.02(a)1
Reinforcing Bars, Epoxy Coated.....	910.01
Support Devices	910.01(b)11
Threaded Tie Bar Assembly.....	910.01(b)2

SECTION 609, BEGIN LINE 37, DELETE AND INSERT AS FOLLOWS:

609.05 Joints

Longitudinal construction joints will only be allowed as shown on the plans. The Type I-A joint shall be constructed as shown on the plans.

Type I-A joints shall be created by sawing slots using sawing equipment in accordance with 508.07. ~~The joint shall be cut in two operations.~~ The initial saw cut shall commence as soon as the concrete has hardened sufficiently to enable sawing without raveling, usually 2 to 12 h after placement.

~~The second saw cut shall be made after the concrete has sufficiently cured, but before opening the RCBA to all traffic.~~ Slurry or saw residue remaining in the slot shall be immediately flushed. Construction traffic shall not be on the RCBA after the ~~second~~ saw cut until the joint is sealed.

The sawed slot shall be cleaned to remove all foreign matter from the entire depth of cut. Joint sealing shall be in accordance with 503.05, *except that either hot poured joint sealant or self-leveling silicone joint sealant may be used.* *The same sealant material shall be used throughout the structure.*

REVISION TO STANDARD SPECIFICATIONS AND STANDARD DRAWINGS

E 609-BRJT-01 TYPE I-A JOINT (WITH MARKUPS)

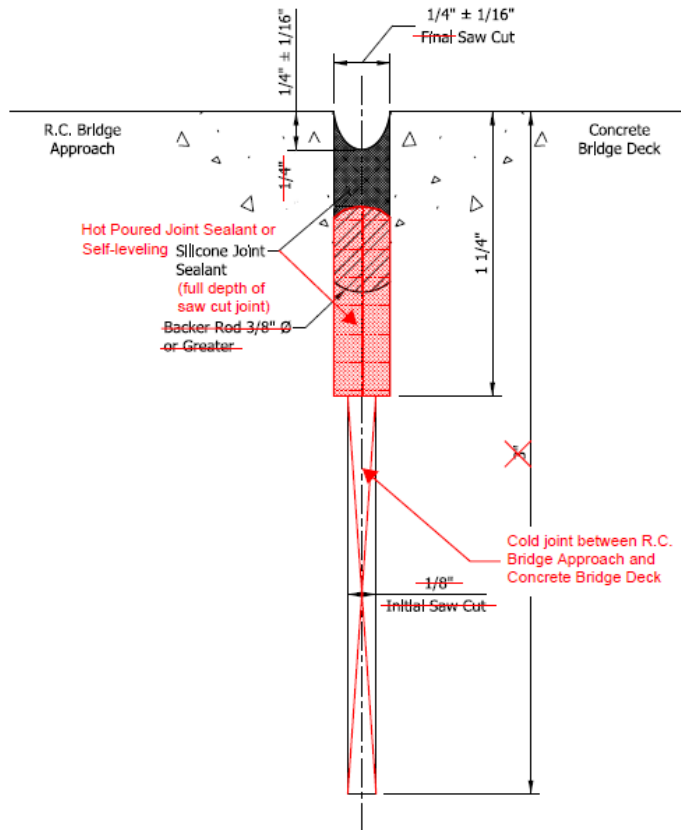

NOTES:

1. See Standard Drawing series E-609-RCBA for joint location.

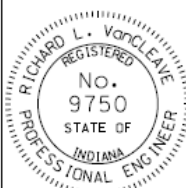
INDIANA DEPARTMENT OF TRANSPORTATION	
TYPE I-A JOINT	
SEPTEMBER 2012	
STANDARD DRAWING NO.	E 609-BRJT-01
	DETAILS PLACED IN THIS FORMAT 09/04/12 /s/ Richard L. VanCleave 09/04/12 SUPERVISOR, ROADWAY STANDARDS DATE /s/ Mark A. Miller 09/04/12 CHIEF ENGINEER DATE

REVISION TO STANDARD SPECIFICATIONS AND STANDARD DRAWINGS

E 609-BRJT-01 TYPE I-A JOINT (PROPOSED DRAFT)

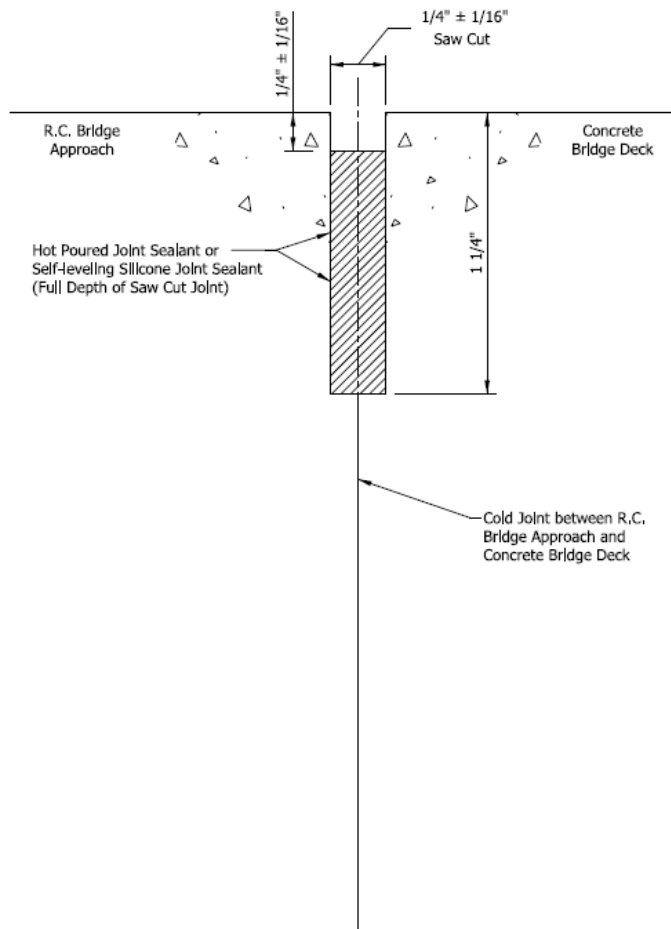

NOTES:

1. See Standard Drawing series E-609-RCBA for joint location.

INDIANA DEPARTMENT OF TRANSPORTATION	
TYPE I-A JOINT	
SEPTEMBER 2023	
STANDARD DRAWING NO.	E 609-BRJT-01
	SUPERVISOR, ROADWAY STANDARDS DATE
	CHIEF ENGINEER DATE

COMMENTS AND ACTION

609.02 Materials

E 609-BRJT-01 TYPE I-A JOINT

DISCUSSION:

This item was introduced and presented by Mr. White who explained that the current detail for Type I-A joints includes a backer rod to limit the depth of silicone sealant to the upper 1/2 in. of the joint, leaving the remaining depth open. Research has shown that this creates a space for moisture to enter once the sealant breaks down, causing the space below the sealant to experience more rapid deterioration of the concrete. Further clarification was provided by Mr. Nelson.

Similar to the current joint details for concrete pavement shown in Standard Drawing series E 503-CCPJ, Mr. White proposed that the backer rod will be eliminated and the saw cut joint will be completely filled with either silicone or hot poured sealant. The Type I-A joint will also be revised to a single saw cut rather than the current two phase cut to facilitate the complete filling of the joint and simplify construction.

Mr. Koch mentioned that silicone seems to act similar to a rubber band. Thin bands are nice and stretchy whereas too thick become rigid. I did not look up all silicone products on the QPL; Crafcro does limit the depth of silicone. Striking the backer rod is a good thing, please consider requiring only hot pour for the joint.

Mr. Nelson responded that he is in favor of hot pour only, yet had a concern that it may create logistical problems on small bridge contracts that may need to deliver very small quantities. If Construction generally has no problem going hot pour only, I support it.

Mr. Koch said that ideally the standard should be updated to show only hot pour as that is the only viable method for new construction but leave silicone available in the material section potentially allowing the material via USP's for specific situations.

Mr. White responded that the only movements that should occur at a Type I-A joint would be caused by rotations of the beam ends under loading. However, I think those should be relatively small and wouldn't likely cause much strain in the joint filling material. Since the RCBA is tied to the superstructure with threaded tie bar assemblies, there shouldn't be any opening and closing of the gap due to thermal movements. In any case, it sounds like everyone is in agreement that hot pour is a better material for this application. Therefore, I'm in favor of only specifying hot pour sealant as long as no one has any concerns with the small quantity that will be required for a stand-alone bridge project.

Following much discussion, it was decided to leave both materials as an option. Minor editorial revisions for clarification are as shown.

Mr. White revised his motion, which was seconded by Mr. Koch.

There was no further discussion and this item passed as revised.

[continued on next page]

COMMENTS AND ACTION

609.02 Materials
E 609-BRJT-01 TYPE I-A JOINT

[continued]

	Action:
Motion: Mr. White Second: Mr. Koch Ayes: 10 Nays: 0 FHWA Approval: YES	— Passed as Submitted <input checked="" type="checkbox"/> Passed as Revised — Withdrawn
2024 Standard Specifications Sections referenced and/or affected: 609.02 pg 520.	<input checked="" type="checkbox"/> 2026 Standard Specifications — Revise Pay Items List — Notification to Designers if change is <u>not</u> addressed by RSP
Recurring Special Provisions or Plan Details: 609-B-311 RCBA Slab Option for Use with Short Term Closures	<input checked="" type="checkbox"/> Create RSP (No. 609-B-322) Effective: December 1, 2023
Standard Drawing affected: E 609-BRJT	<input checked="" type="checkbox"/> Revise RSP (No. 609-B-311) Effective: December 1, 2023
Design Manual Sections affected: Chapter 409 show the location of Type I-A joints, but none contain enough detail to require a revision.	<input checked="" type="checkbox"/> Standard Drawing E 609-BRJT-01 Effective: September 1, 2024 <input checked="" type="checkbox"/> Create RPD (No. 609-B-322d) Effective: December 1, 2023
GIFE Sections cross-references: NONE	— GIFE Update <input checked="" type="checkbox"/> Frequency Manual Update <input checked="" type="checkbox"/> SiteManager Update

PROPOSAL TO STANDARDS COMMITTEE

PROBLEM(S) ENCOUNTERED: confusion exists in the 502 and 506 spec sections on the minimum opening to traffic concrete strength depending on which concrete mix is used.

PROPOSED SOLUTION: incorporate the proposed edits to the 502 and 506 sections which are believed to clarify the situation

APPLICABLE STANDARD SPECIFICATIONS: 502, 506

APPLICABLE STANDARD DRAWINGS: none

APPLICABLE DESIGN MANUAL SECTION: none

APPLICABLE SECTION OF GIFE: none

APPLICABLE RECURRING SPECIAL PROVISIONS: create a new RSP

PAY ITEMS AFFECTED: none

APPLICABLE SUB-COMMITTEE ENDORSEMENT: Ad hoc: Nathan Butts, Mike Nelson, Jim Reilman

IF APPROVED AS RECURRING SPECIAL PROVISION OR PLAN DETAILS, PROPOSED BASIS FOR USE:

IMPACT ANALYSIS (attach report):

Submitted By: Jim Reilman

Title: State Materials Engineer

Organization: INDOT

Phone Number: (317) 522-9692

Date: 6/28/23

IMPACT ANALYSIS REPORT CHECKLIST

Explain the business case as to why this item should be presented to the Standards Committee for approval. Answer the following questions with Yes, No or N/A.

Does this item appear in any other specification sections? No

Will approval of this item affect the Approved Materials List? No

Will this proposal improve:

Construction costs? N/A

Construction time? N/A

Customer satisfaction? Yes

Congestion/travel time? N/A

Ride quality? N/A

Will this proposal reduce operational costs or maintenance effort? N/A

Will this item improve safety:

For motorists? N/A

For construction workers? N/A

Will this proposal improve quality for:

Construction procedures/processes? N/A

Asset preservation? N/A

Design process? N/A

Will this change provide the contractor more flexibility? N/A

Will this proposal provide clarification for the Contractor and field personnel? Yes

Can this item improve/reduce the number of potential change orders? N/A

Is this proposal needed for compliance with:

Federal or State regulations? No

AASHTO or other design code? No

Is this item editorial? No

Provide any further information as to why this proposal should be placed on the Standards Committee meeting Agenda:

REVISION TO STANDARD SPECIFICATIONS

SECTION 502 – PORTLAND CEMENT CONCRETE PAVEMENT, PCCP
502.04 Concrete Mix Criteria
SECTION 506 – PCCP PATCHING
506.06 Job Control
506.12 Opening to Traffic

(Note: Proposed changes shown highlighted gray)

The Standard Specifications are revised as follows:

SECTION 502, BEGIN LINE 74, DELETE AS FOLLOWS:

502.04 Concrete Mix Criteria

Chemical admixtures Type A, Type B, Type C, Type D, Type E, and Type F may be allowed if shown on the CMDP. The supplied concrete mix shall include one of the following water reducing admixtures: Type A, Type D, Type E, or Type F.

(a) Portland Cement Concrete

The CMD shall produce workable concrete mixtures, with the minimum amount of water, and having the following properties.

Targets for the CMD:

Portland cement content.....	564 lb/cu yd ^A
Minimum water/cementitious ratio.....	0.340 ^B
Maximum water/cementitious ratio.....	0.435 ^B
Maximum portland cement reduction for slag cement replacement.....	30%
Slag cement/portland cement substitution ratio.....	1.00 by weight
Maximum cement reduction for fly ash replacement.....	20%
Fly ash/portland cement substitution ratio.....	1.25 by weight
Air Content.....	6.5%
Minimum modulus of rupture.....	570 psi at 7 days ^C
Relative Yield.....	1.00

Field Acceptance Properties:

Minimum water/cementitious ratio.....	0.320 ^B
Maximum water/cementitious ratio.....	0.450 ^B
Slump, formed.....	2 to 6 in.
Slump, slipformed.....	1.25 to 3 in.
Air Content.....	5.0% to 8.0%
Minimum modulus of rupture.....	570 psi at 7 days ^C
Relative Yield.....	0.98 to 1.02

^A The target cement content during production shall not be adjusted from the value stated on the CMDP.

^B The water cementitious ratio during production shall not

REVISION TO STANDARD SPECIFICATIONS

SECTION 502 – PORTLAND CEMENT CONCRETE PAVEMENT, PCCP

502.04 Concrete Mix Criteria

SECTION 506 – PCCP PATCHING

506.06 Job Control

506.12 Opening to Traffic

deviate more than 0.020 from the target stated in the CMDP and shall not fall outside the limits above.

^C Beams shall be standard cured in a water tank in accordance with AASHTO T 23 and 505.01(a). The water does not need to be saturated with calcium hydroxide. ~~Minimum flexural strength for opening to traffic shall be in accordance with 506.12.~~

SECTION 506, BEGIN LINE 310, DELETE AND INSERT AS FOLLOWS:

506.06 Job Control

Control of PCCP for air content, relative yield, and flexural strength beams will be determined from tests performed by the Engineer in accordance with 505. Concrete and necessary labor for sampling shall be furnished as required by the Engineer. Testing for air content and relative yield will be on the first load of the day and once per every 50 cu yds.

(a) Beams for Validation of CMDP

At least one set, consisting of ~~three~~two beams per set, will be made once per every 150 cu yds of concrete placed and tested for compliance with either the 3-day or 7-day flexural strength requirements in accordance with 506.04(b) or 502.04(a) respectively, for the purpose of CMDP validation. Air content and relative yield will be measured on each sample of concrete from which beams are made.

SECTION 506, BEGIN LINE 559, DELETE AS FOLLOWS:

506.12 Opening to Traffic

For purposes of this section, traffic shall include construction vehicles, construction equipment, and all non-construction vehicles. Any construction vehicle or equipment that may damage the PCCP shall not be used on the PCCP unless adequate protection is provided. Joint cutting saws may be operated on the PCCP as determined by the Contractor.

(a) For Patches Less than or Equal to 15 ft in Length

A patch may be opened to traffic in accordance with the following when calcium chloride is used in accordance with 506.04(a).

T	H	HT	T	H	HT
40 - 42°F	30	26	61 - 63°F	14	9
43 - 45°F	27	23	64 - 66°F	14	9
46 - 48°F	24	21	67 - 69°F	14	8
49 - 51°F	21	19	70 - 72°F	14	7
52 - 54°F	19	16	73 - 75°F	14	6
55 - 57°F	16	14	above 75°F	14	5
58 - 60°F	16	11			

REVISION TO STANDARD SPECIFICATIONS

SECTION 502 – PORTLAND CEMENT CONCRETE PAVEMENT, PCCP
502.04 Concrete Mix Criteria
SECTION 506 – PCCP PATCHING
506.06 Job Control
506.12 Opening to Traffic

T = Lowest ambient temperature during placement, or the temperature of concrete at time of delivery, whichever is lower.
H = Time in hours to open to traffic.
HT = Time in hours to open to traffic when the average daily traffic is less than 10,000.

PCCP patches with calcium chloride may be opened to traffic sooner than specified in the above table if test beams indicate a modulus of rupture of 300 psi or greater. ITM 402 may be used as an alternative method to determine the flexural strength.

When other admixtures or admixture systems are used, the PCCP patches may be opened to traffic when flexural strength tests indicate a modulus of rupture of 300 psi or greater. ITM 402 may be used as an alternate method to determine the flexural strength.

(b) For Patches Greater than 15 ft in Length

Traffic shall not be allowed on the PCCP until a modulus of rupture of 425 psi from flexural strength testing in accordance with the appropriate value in the table below is achieved. The modulus of rupture will be determined by averaging two beams.

<i>Concrete Mix in accordance with:</i>	<i>Minimum Modulus of Rupture, psi</i>
502.04(a)	550
506.04(b)	425

COMMENTS AND ACTION

502.04 Concrete Mix Criteria
 506.06 Job Control
 506.12 Opening to Traffic

DISCUSSION:

Mr. Reilman introduced and presented this item stating that confusion exists in the 502 and 506 spec sections on the minimum opening to traffic concrete strength depending on which concrete mix is used. Further clarification was provided by Mr. Nelson.

Mr. Reilman proposed to incorporate the proposed edits to the 502 and 506 sections which are intended to clarify the situation.

There was no further discussion and this item passed as submitted.

<p>Motion: Mr. Reilman Second: Mr. Pelz Ayes: 10 Nays: 0 FHWA Approval: YES</p>	<p>Action: <input checked="" type="checkbox"/> Passed as Submitted <input type="checkbox"/> Passed as Revised <input type="checkbox"/> Withdrawn</p>
<p>2024 Standard Specifications Sections referenced and/or affected: 502.04 pg 424; 506 pg 450, 452</p>	<p><input checked="" type="checkbox"/> 2026 Standard Specifications Revise Pay Items List Notification to Designers if change is <u>not</u> addressed by RSP</p>
<p>Recurring Special Provisions or Plan Details: NONE</p>	<p><input checked="" type="checkbox"/> Create RSP (No. <u>502-R-761 and 506-R-762</u>) Effective: <u>December 1, 2023</u></p>
<p>Standard Drawing affected: NONE</p>	<p><input type="checkbox"/> Revise RSP (No. __) Effective:</p>
<p>Design Manual Sections affected: NONE</p>	<p><input type="checkbox"/> Standard Drawing Effective:</p>
<p>GIFE Sections cross-references: NONE</p>	<p><input type="checkbox"/> Create RPD (No. __) Effective:</p>
	<p><input type="checkbox"/> GIFE Update <input type="checkbox"/> Frequency Manual Update <input type="checkbox"/> SiteManager Update</p>

PROPOSAL TO STANDARDS COMMITTEE

PROBLEM(S) ENCOUNTERED: Typical industry nomenclature uses the term "coating" instead of paint as most of these products are not actually paints. Updates are needed to the Partial Paint System material products.

PROPOSED SOLUTION: Change the term "paint" to "coating" in most places in 619 and 909 as shown. Incorporate updates to the Partial Paint System and delete RSP 619-B-314. Other editorial cleanup.

APPLICABLE STANDARD SPECIFICATIONS: Section 101, 104, 202, 203, 604, 619, 711, 712, 729, 801, 802, 805, 807, 909

APPLICABLE STANDARD DRAWINGS: E619-PRBE-01.

APPLICABLE DESIGN MANUAL SECTION: Chapter 17, 107, 402, 407, 410, and 412.

APPLICABLE SECTION OF GIFE: Chapter 5

APPLICABLE RECURRING SPECIAL PROVISIONS: 619-B-314

PAY ITEMS AFFECTED: None

APPLICABLE SUB-COMMITTEE ENDORSEMENT: Ad hoc: Kelly Cummins, Jim Reilman

IF APPROVED AS RECURRING SPECIAL PROVISION OR PLAN DETAILS, PROPOSED BASIS FOR USE:
All contracts with a 604, 619, 620, 711, 712, 729, or 802 pay item.

IMPACT ANALYSIS (attach report):

Submitted By: Jim Reilman

Title: State Materials Engineer

Organization: INDOT

Phone Number: (317) 522-9692

Date: 6/26/23

IMPACT ANALYSIS REPORT CHECKLIST

Explain the business case as to why this item should be presented to the Standards Committee for approval. Answer the following questions with Yes, No or N/A.

Does this item appear in any other specification sections? No

Will approval of this item affect the Approved Materials List? Yes

Will this proposal improve:

Construction costs? Yes

Construction time? Yes

Customer satisfaction? N/A

Congestion/travel time? N/A

Ride quality? N/A

Will this proposal reduce operational costs or maintenance effort? N/A

Will this item improve safety:

For motorists? N/A

For construction workers? N/A

Will this proposal improve quality for:

Construction procedures/processes? Yes

Asset preservation? N/A

Design process? N/A

Will this change provide the contractor more flexibility? Yes

Will this proposal provide clarification for the Contractor and field personnel? Yes

Can this item improve/reduce the number of potential change orders? Yes

Is this proposal needed for compliance with:

Federal or State regulations? No

AASHTO or other design code? No

Is this item editorial? No

Provide any further information as to why this proposal should be placed on the Standards Committee meeting Agenda:

REVISION TO STANDARD SPECIFICATIONS AND SPECIAL PROVISIONS

- SECTION 101 – DEFINITIONS AND TERMS
- SECTION 104 – SCOPE OF WORK
- SECTION 202 – REMOVAL OF STRUCTURES AND OBSTRUCTIONS
- SECTION 203 – EXCAVATION AND EMBANKMENT
- SECTION 604 – SIDEWALKS, CURB RAMPS, STEPS, AND HANDRAILS
- SECTION 619 – COATING BRIDGE STEEL
- SECTION 711 – STEEL STRUCTURES
- SECTION 712 – TIMBER STRUCTURES
- SECTION 729 – HEAT STRAIGHTENING OF STEEL MEMBERS IN THE FIELD
- SECTION 801 – TRAFFIC CONTROLS FOR CONSTRUCTION AND MAINTENANCE OPERATIONS
- SECTION 802 – SIGNS
- SECTION 805 – TRAFFIC SIGNALS
- SECTION 807 – HIGHWAY ILLUMINATION
- SECTION 909 – COATINGS, PAINTS, AND LIQUID EPOXY
- 619-B-314 ALTERNATE FINISH COAT FOR PARTIAL PAINT SYSTEM (PROPOSED TO DISCONTINUE)
- 620-R-483 SOUND BARRIER SYSTEMS

(Note: Proposed changes shown highlighted gray)

The Standard Specifications are revised as follows:

SECTION 101, BEGIN LINE 544, INSERT AS FOLLOWS:

101.76 Wastewater

Water containing waste residue from paint, *coatings*, form release oils, curing compounds and other construction debris, as well as soaps, detergents or solvents used in vehicle, equipment and structure washing, or other material defined as illicit discharge in accordance with the Indiana Municipal Storm Sewer General Permit, MS4GP. This includes untreated sediment-laden stormwater and wastewater associated with liquid waste from concrete, grout, mortar, stucco, and other similar construction materials resulting from concrete washout, hydrodemolition, saw cutting, coring, or dewatering operations contaminated by concrete pours or similar activities.

SECTION 104, BEGIN LINE 383, INSERT AS FOLLOWS:

104.06 Removal and Disposal of Regulated Materials

The removal, testing, transportation, or disposal of regulated materials, except for paint *and coating* removal and disposal operations described in 619, shall be in accordance with the requirements included herein and the applicable Federal, State, and local laws, regulations, and rules. These include, but will not be limited to, the requirements of the Federal Toxic Substances Control Act, the Federal Resource Conservation Recovery Act, the Federal Comprehensive Environmental Response Compensation Liability Act, OSHA, IDEM, and State rules requiring certification of underground storage tank removal firms.

SECTION 202, BEGIN LINE 13, ~~DELETE AND~~ INSERT AS FOLLOWS:

202.02 General Requirements

All buildings and foundations in accordance with 202.06, structures, fences, tanks, and other obstructions, any portions of which are on the right-of-way shall be razed, removed, and disposed of, except utilities and those features for which other provisions have been made for removal. Salvageable material designated by the Department shall be removed without unnecessary damage in sections or pieces which may be transported readily and shall be stored at specified places within the project limits or as otherwise designated.

REVISION TO STANDARD SPECIFICATIONS AND SPECIAL PROVISIONS

- SECTION 101 – DEFINITIONS AND TERMS
- SECTION 104 – SCOPE OF WORK
- SECTION 202 – REMOVAL OF STRUCTURES AND OBSTRUCTIONS
- SECTION 203 – EXCAVATION AND EMBANKMENT
- SECTION 604 – SIDEWALKS, CURB RAMPS, STEPS, AND HANDRAILS
- SECTION 619 – COATING BRIDGE STEEL
- SECTION 711 – STEEL STRUCTURES
- SECTION 712 – TIMBER STRUCTURES
- SECTION 729 – HEAT STRAIGHTENING OF STEEL MEMBERS IN THE FIELD
- SECTION 801 – TRAFFIC CONTROLS FOR CONSTRUCTION AND MAINTENANCE OPERATIONS
- SECTION 802 – SIGNS
- SECTION 805 – TRAFFIC SIGNALS
- SECTION 807 – HIGHWAY ILLUMINATION
- SECTION 909 – COATINGS, PAINTS, AND LIQUID EPOXY
- 619-B-314 ALTERNATE FINISH COAT FOR PARTIAL PAINT SYSTEM (PROPOSED TO DISCONTINUE)
- 620-R-483 SOUND BARRIER SYSTEMS

Materials not designated by the Department as salvageable and removed from the construction site shall become the property of the Contractor and shall be disposed of in accordance with 203.08. Regulated materials shall be disposed of in accordance with 104.06. Bridge painting *and coating* debris shall be disposed of in accordance with 619.

SECTION 203, BEGIN LINE 65, ~~DELETE AND~~ INSERT AS FOLLOWS:

Disposal of material, other than regulated material and bridge painting debris, from within the right-of-way shall only be allowed at accepted locations. Disposal of regulated material shall be in accordance with 104.06. Disposal of bridge painting *and coating* debris shall be in accordance with 619.

SECTION 604, BEGIN LINE 9, INSERT AS FOLLOWS:

604.02 Materials

Materials shall be in accordance with the following:

Coarse Aggregate, Class D or Higher, Size No. 53	904.03
Concrete, Class A.....	702
Detectable Warning Surfaces.....	905.05
Fine Aggregate, Size No. 23, No. 24, or No. 15	904.02
Joint Filler	906.01
Joint Sealing Materials.....	906.02
Reinforcing Bars	910.01
Silica Sand.....	ASTM C778
<i>Structural Steel Coating System.....</i>	<i>909.03</i>

Hand railing shall be aluminum pipe in accordance with ASTM B221, alloy 6063, temper T52, or galvanized steel pipe in accordance with ASTM A53, grade B, all as specified. *Railing designated to be painted shall be coated with the structural steel coating system with the exception that the epoxy intermediate coat will not be required.*

The detectable warning surface in concrete curb ramps shall be selected from the QPL of Detectable Warning Surfaces in accordance with 905.05.

REVISION TO STANDARD SPECIFICATIONS AND SPECIAL PROVISIONS

SECTION 101 – DEFINITIONS AND TERMS
 SECTION 104 – SCOPE OF WORK
 SECTION 202 – REMOVAL OF STRUCTURES AND OBSTRUCTIONS
 SECTION 203 – EXCAVATION AND EMBANKMENT
 SECTION 604 – SIDEWALKS, CURB RAMPS, STEPS, AND HANDRAILS
 SECTION 619 – COATING BRIDGE STEEL
 SECTION 711 – STEEL STRUCTURES
 SECTION 712 – TIMBER STRUCTURES
 SECTION 729 – HEAT STRAIGHTENING OF STEEL MEMBERS IN THE FIELD
 SECTION 801 – TRAFFIC CONTROLS FOR CONSTRUCTION AND MAINTENANCE OPERATIONS
 SECTION 802 – SIGNS
 SECTION 805 – TRAFFIC SIGNALS
 SECTION 807 – HIGHWAY ILLUMINATION
 SECTION 909 – COATINGS, PAINTS, AND LIQUID EPOXY
 619-B-314 ALTERNATE FINISH COAT FOR PARTIAL PAINT SYSTEM (PROPOSED TO DISCONTINUE)
 620-R-483 SOUND BARRIER SYSTEMS

SECTION 604, BEGIN LINE 230, DELETE AND INSERT AS FOLLOWS:

604.09 Handrails

This railing shall be erected in a workmanlike manner, straight and true to grade. Posts shall be vertical and railings shall be parallel to the walk surface or the plane of the steps and spaced as shown on the plans. Fastenings shall be as shown on the plans. Railing posts on masonry shall be held in place in a manner that develops the full strength of the railing post in bending.

Fabrication and placement of railings shall be completed in accordance with the applicable requirements of 711. Ends of tube sections shall be milled or sawed. Cut ends shall be true, smooth, and free from burrs and ragged edges. Welds shall be ground smooth. The rail system shall be continuous except as shown on the plans. Joints shall be spliced as detailed on the plans. Welding of steel shall be in accordance with 711.32 and welding of aluminum shall be in accordance with the applicable requirements of 803. Radiographic, magnetic particle, and dye penetrant inspection will not be required.

All aluminum surfaces in contact with concrete shall be coated with an aluminum impregnated caulking compound prior to installation. After installation and alignment, openings between metal surfaces and concrete shall be sealed in a watertight manner with the caulking compound.

~~Steel pipe railing not designated to be painted shall be galvanized after fabrication and prior to installation. Railing designated to be painted shall receive one shop coat of paint after fabrication and two field coats after installation. The type and color of paint shall be as specified on the plans. Cleaning and painting shall be in accordance with 619. The surface of galvanized steel railing designated on the plans to be painted with a coating shall be prepared using a light brush-off blast cleaning in accordance with SSPC-SP16. The resulting surface profile shall be 15 to 30 microns in accordance with ASTM D4417. Primer in accordance with 909.02(a)1 shall then be shop-applied prior to delivery to the jobsite. The polyurethane finish coat shall be in accordance with 909.02(c) and shall be applied after the railing installation. The color of the dry film of the finish coat shall be as shown on the plans. Applying coatings shall be in accordance with the applicable portions of 619.~~

REVISION TO STANDARD SPECIFICATIONS AND SPECIAL PROVISIONS

- SECTION 101 – DEFINITIONS AND TERMS
- SECTION 104 – SCOPE OF WORK
- SECTION 202 – REMOVAL OF STRUCTURES AND OBSTRUCTIONS
- SECTION 203 – EXCAVATION AND EMBANKMENT
- SECTION 604 – SIDEWALKS, CURB RAMPS, STEPS, AND HANDRAILS
- SECTION 619 – COATING BRIDGE STEEL
- SECTION 711 – STEEL STRUCTURES
- SECTION 712 – TIMBER STRUCTURES
- SECTION 729 – HEAT STRAIGHTENING OF STEEL MEMBERS IN THE FIELD
- SECTION 801 – TRAFFIC CONTROLS FOR CONSTRUCTION AND MAINTENANCE OPERATIONS
- SECTION 802 – SIGNS
- SECTION 805 – TRAFFIC SIGNALS
- SECTION 807 – HIGHWAY ILLUMINATION
- SECTION 909 – COATINGS, PAINTS, AND LIQUID EPOXY
- 619-B-314 ALTERNATE FINISH COAT FOR PARTIAL PAINT SYSTEM (PROPOSED TO DISCONTINUE)
- 620-R-483 SOUND BARRIER SYSTEMS

SECTION 604, BEGIN LINE 339, DELETE AND INSERT AS FOLLOWS:

The cost of removal, disposal, and replacement of portions of the concrete curb ramp, concrete base, including border, detectable warning surfaces, thin set mortar, and fine aggregate for filling joints shall be included in the cost of the detectable warning surfaces, retrofit.

The cost of aluminum impregnated caulking compound and the paintingcoating of steel hand railing shall be included in the cost of the handrail.

SECTION 619, BEGIN LINE 1, DELETE AND INSERT AS FOLLOWS:

SECTION 619 – PAINTINGCOATING BRIDGE STEEL

619.01 Description

This work shall consist of preparing surfaces, disposing of waste, and applying a paint or another coating to steel bridges, steel piling, bearing assemblies, or other steel items in accordance with 105.03.

MATERIALS

619.02 Materials

Materials shall be in accordance with the following:

Epoxy Intermediate PaintCoat	909.02(b)
Finish Coat for Weathering Steel.....	909.02(e)
Multi-Component Inorganic Zinc Silicate Primer	909.02(a)1
Organic Zinc Primer.....	909.02(a)2
Polyurethane Finish Coat	909.02(c)
Structural Steel Coating Systems.....	909.03
Waterborne Finish PaintCoat.....	909.02(d)

Safety data sheets shall be provided in the QCP for all materials to be delivered to the project site.

REVISION TO STANDARD SPECIFICATIONS AND SPECIAL PROVISIONS

SECTION 101 – DEFINITIONS AND TERMS
 SECTION 104 – SCOPE OF WORK
 SECTION 202 – REMOVAL OF STRUCTURES AND OBSTRUCTIONS
 SECTION 203 – EXCAVATION AND EMBANKMENT
 SECTION 604 – SIDEWALKS, CURB RAMPS, STEPS, AND HANDRAILS
 SECTION 619 – COATING BRIDGE STEEL
 SECTION 711 – STEEL STRUCTURES
 SECTION 712 – TIMBER STRUCTURES
 SECTION 729 – HEAT STRAIGHTENING OF STEEL MEMBERS IN THE FIELD
 SECTION 801 – TRAFFIC CONTROLS FOR CONSTRUCTION AND MAINTENANCE OPERATIONS
 SECTION 802 – SIGNS
 SECTION 805 – TRAFFIC SIGNALS
 SECTION 807 – HIGHWAY ILLUMINATION
 SECTION 909 – COATINGS, PAINTS, AND LIQUID EPOXY
 619-B-314 ALTERNATE FINISH COAT FOR PARTIAL PAINT SYSTEM (PROPOSED TO DISCONTINUE)
 620-R-483 SOUND BARRIER SYSTEMS

Caulk used to form the drip bead on weathering steel shall be a clear, 100% silicone caulk.

Caulk used on joints of lapping members shall be compatible with either the structural steel ~~paintcoating~~ system or the partial ~~paintcoating~~ system, and in accordance with the ~~paintcoating~~ manufacturer's recommendations.

CONSTRUCTION REQUIREMENTS

619.03 Quality Control and Quality Assurance

The Contractor shall be responsible for the quality of work on the contract and shall ensure that all work has been performed by accepted quality control methods. A QCP shall be prepared and submitted by the Contractor in accordance with ITM 803. No work may begin until written notice has been received that the QCP was accepted by the Engineer. The QC manager shall furnish the current referenced SSPC Standards at the project site.

Cleaning and ~~painting~~ *applying a coating* shall be done by a Contractor certified as SSPC-QP 2 ~~for cleaning and painting existing bridge steel~~ on steel structures shown in the contract documents as being built before 1995. Cleaning and ~~painting~~ *applying a coating* shall be ~~done~~ *performed* by a Contractor that, at a minimum, is certified as SSPC-QP 1 ~~for cleaning and painting new bridge steel or for cleaning and painting existing bridge steel~~ on steel structures shown in the contract documents as being built after 1994.

SECTION 619, BEGIN LINE 80, DELETE AND INSERT AS FOLLOWS:

(b) Acceptance Testing

Acceptance testing of ~~painting for the coating of~~ steel bridges ~~work~~ will be in accordance with ITM 803. The results of the acceptance testing will be compared to the specific requirements for that phase of work. The Contractor shall not proceed to the next phase of work until written approval has been received from the Engineer that the current phase is accepted.

619.04 Prosecution of Work

Prosecution of work shall be in accordance with the applicable requirements of 108.04. Once the cleaning and ~~painting~~ *coating* operations have begun, it shall be performed

REVISION TO STANDARD SPECIFICATIONS AND SPECIAL PROVISIONS

SECTION 101 – DEFINITIONS AND TERMS
 SECTION 104 – SCOPE OF WORK
 SECTION 202 – REMOVAL OF STRUCTURES AND OBSTRUCTIONS
 SECTION 203 – EXCAVATION AND EMBANKMENT
 SECTION 604 – SIDEWALKS, CURB RAMPS, STEPS, AND HANDRAILS
 SECTION 619 – COATING BRIDGE STEEL
 SECTION 711 – STEEL STRUCTURES
 SECTION 712 – TIMBER STRUCTURES
 SECTION 729 – HEAT STRAIGHTENING OF STEEL MEMBERS IN THE FIELD
 SECTION 801 – TRAFFIC CONTROLS FOR CONSTRUCTION AND MAINTENANCE OPERATIONS
 SECTION 802 – SIGNS
 SECTION 805 – TRAFFIC SIGNALS
 SECTION 807 – HIGHWAY ILLUMINATION
 SECTION 909 – COATINGS, PAINTS, AND LIQUID EPOXY
 619-B-314 ALTERNATE FINISH COAT FOR PARTIAL PAINT SYSTEM (PROPOSED TO DISCONTINUE)
 620-R-483 SOUND BARRIER SYSTEMS

on all work days without stoppage until all work has been completed. If the contract contains more than one bridge, a schedule shall be included in the QCP which provides the sequence of work on the bridges. Once work has begun on a bridge, it shall be performed until complete, including all cleanup. When cleaning and ~~painting~~ coating beam ends for encasement in concrete is specified, that work may be performed as a separate operation.

SECTION 619, BEGIN LINE 113, DELETE AND INSERT AS FOLLOWS:

619.06 Maintaining Traffic

~~The~~ Traffic lanes may be restricted when surface preparation or ~~painting~~ coating phases are being performed on a portion of the bridge over the traveled roadway, or as directed, when the need exists.

SECTION 619, BEGIN LINE 130, DELETE AND INSERT AS FOLLOWS:

619.07 Safety and Environmental Requirements

Safety requirements, pollution control, and disposal of existing ~~paint~~ coating waste and debris shall be in accordance with the following requirements.

SECTION 619, BEGIN LINE 170, DELETE AND INSERT AS FOLLOWS:

a. Containment for Structures Built Before 1995

For structures shown in the contract documents as being built before 1995, the Contractor shall provide a containment system in order to contain all blasting materials, scrapings, wire brushings, and ~~paint~~ coating particles in accordance with SSPC-Guide 6, Class 2A or greater with method A, level 1 emission control capability. The Contractor shall take samples and monitor the work environment in accordance with IOSHA requirements and shall provide personal protective equipment appropriate to the conditions present within the work environment.

b. Containment for Structures Built After 1994

For structures shown in the contract documents as being built after 1994, the Contractor shall provide a containment system in order to contain all blasting materials, scrapings, wire brushings, and ~~paint~~ coating particles in accordance with SSPC-Guide 6, Class 2A or greater with method A, level 3 emission control capability. The Contractor shall take samples and monitor the work environment in accordance with IOSHA requirements and shall provide personal protective equipment appropriate to the conditions present within

REVISION TO STANDARD SPECIFICATIONS AND SPECIAL PROVISIONS

SECTION 101 – DEFINITIONS AND TERMS
 SECTION 104 – SCOPE OF WORK
 SECTION 202 – REMOVAL OF STRUCTURES AND OBSTRUCTIONS
 SECTION 203 – EXCAVATION AND EMBANKMENT
 SECTION 604 – SIDEWALKS, CURB RAMPS, STEPS, AND HANDRAILS
 SECTION 619 – COATING BRIDGE STEEL
 SECTION 711 – STEEL STRUCTURES
 SECTION 712 – TIMBER STRUCTURES
 SECTION 729 – HEAT STRAIGHTENING OF STEEL MEMBERS IN THE FIELD
 SECTION 801 – TRAFFIC CONTROLS FOR CONSTRUCTION AND MAINTENANCE OPERATIONS
 SECTION 802 – SIGNS
 SECTION 805 – TRAFFIC SIGNALS
 SECTION 807 – HIGHWAY ILLUMINATION
 SECTION 909 – COATINGS, PAINTS, AND LIQUID EPOXY
 619-B-314 ALTERNATE FINISH COAT FOR PARTIAL PAINT SYSTEM (PROPOSED TO DISCONTINUE)
 620-R-483 SOUND BARRIER SYSTEMS

the work environment.

Regardless of the level of containment as listed above, if a spill, as defined in IDEM Regulation 327 IAC 2-6.1 does occur, all work shall stop and immediate action shall be taken to clean up the site. Spills of material, that enter or threaten to enter the water, shall be handled in accordance with IDEM Regulation 327 IAC 2-6.1. The IDEM Emergency Response Branch, the local health department, and all water intake users within 500 ft of the bridge shall be immediately contacted and advised of the spill. Written documentation of all such contacts and actions shall be kept. All applicable Federal, State, and local rules and regulations described in 619.07(b)2b(1) shall be observed.

SECTION 619, BEGIN LINE 240, DELETE AND INSERT AS FOLLOWS:

b. Waste Disposal

Regardless of the waste characterization obtained from the waste stream sample, disposal of existing ~~paintcoating~~ and debris shall be in accordance with SSPC-Guide 7 and the following requirements.

(1) Laws to be Observed

Federal and State laws and regulations regulate the disposal of bridge ~~paintingcoating~~ debris. Bridge ~~paintcoating~~ debris shall be manifested or certified and shall be disposed of at an appropriate disposal facility.

SECTION 619, BEGIN LINE 275, DELETE AND INSERT AS FOLLOWS:

(3) Marking of Spent Material Containers

Spent material containers shall be marked with the date that waste is first placed in the container. Until laboratory results described in 619.07(b)2a are received concerning the category of the waste stream, the containers shall be labeled “LEAD ~~PAINTCOATING~~ WASTE DEBRIS” or “ZINC ~~PAINTCOATING~~ WASTE DEBRIS”, as appropriate. The labeling shall include the contract number, bridge number, sample number, and sample date. Labeling of containers as hazardous waste will not be required until the appropriate laboratory analysis determines the waste stream to be hazardous in accordance with the current RCRA hazardous waste definitions. Immediately upon notice that the waste is hazardous, the containers shall be marked in accordance with 49 CFR 172, Subpart D.

REVISION TO STANDARD SPECIFICATIONS AND SPECIAL PROVISIONS

SECTION 101 – DEFINITIONS AND TERMS
 SECTION 104 – SCOPE OF WORK
 SECTION 202 – REMOVAL OF STRUCTURES AND OBSTRUCTIONS
 SECTION 203 – EXCAVATION AND EMBANKMENT
 SECTION 604 – SIDEWALKS, CURB RAMPS, STEPS, AND HANDRAILS
 SECTION 619 – COATING BRIDGE STEEL
 SECTION 711 – STEEL STRUCTURES
 SECTION 712 – TIMBER STRUCTURES
 SECTION 729 – HEAT STRAIGHTENING OF STEEL MEMBERS IN THE FIELD
 SECTION 801 – TRAFFIC CONTROLS FOR CONSTRUCTION AND MAINTENANCE OPERATIONS
 SECTION 802 – SIGNS
 SECTION 805 – TRAFFIC SIGNALS
 SECTION 807 – HIGHWAY ILLUMINATION
 SECTION 909 – COATINGS, PAINTS, AND LIQUID EPOXY
 619-B-314 ALTERNATE FINISH COAT FOR PARTIAL PAINT SYSTEM (PROPOSED TO DISCONTINUE)
 620-R-483 SOUND BARRIER SYSTEMS

(4) Instruction for Disposal of Paint Coating Waste

If the waste stream is found to be hazardous, the Engineer will obtain an EPA identification number from IDEM. This number will be provided to the Contractor within 30 days of the start of waste generation for bridges having hazardous waste paintcoating debris. The waste from different bridges shall not be commingled. The Contractor shall be responsible for:

SECTION 619, BEGIN LINE 325, DELETE AND INSERT AS FOLLOWS:

(5) Instructions for Disposal of Other Project Generated Waste

Other wastes that may be generated on the project include, but are not limited to, spent solvents from cleaning of equipment and empty or partially empty containers of paintcoating, paint thinners, spent abrasives, and solvents. The Contractor shall recycle or dispose of all project generated waste materials.

SECTION 619, BEGIN LINE 337, DELETE AND INSERT AS FOLLOWS:

619.08 Surface Preparation of Concrete and Steel

The tops of all concrete and steel pier caps, concrete abutment caps, and 2 ft down all sides of concrete pier and abutment caps shall be washed. The washing shall be accomplished by means of a pressure washer with potable water. The pressure shall be between 800 and 1,500 psi. If detergents or other additives are added to the water, the surface shall be rinsed with potable water before the detergents dry.

Cleaning of steel surfaces shall be performed by an SSPC certified contractor. This requirement will not apply to the following:

- (1) shop cleaning; or
- (2) sections of beams or other structural members less than 180 sq ft of total area to be paintedcoated for the contract where heat-straightening or similar repairs have taken place.

Surfaces to be paintedcoated shall be cleaned in accordance with the SSPC classification, unless otherwise specified. Compressed air shall pass through an oil and water extractor before entering another apparatus.

REVISION TO STANDARD SPECIFICATIONS AND SPECIAL PROVISIONS

SECTION 101 – DEFINITIONS AND TERMS
 SECTION 104 – SCOPE OF WORK
 SECTION 202 – REMOVAL OF STRUCTURES AND OBSTRUCTIONS
 SECTION 203 – EXCAVATION AND EMBANKMENT
 SECTION 604 – SIDEWALKS, CURB RAMPS, STEPS, AND HANDRAILS
 SECTION 619 – COATING BRIDGE STEEL
 SECTION 711 – STEEL STRUCTURES
 SECTION 712 – TIMBER STRUCTURES
 SECTION 729 – HEAT STRAIGHTENING OF STEEL MEMBERS IN THE FIELD
 SECTION 801 – TRAFFIC CONTROLS FOR CONSTRUCTION AND MAINTENANCE OPERATIONS
 SECTION 802 – SIGNS
 SECTION 805 – TRAFFIC SIGNALS
 SECTION 807 – HIGHWAY ILLUMINATION
 SECTION 909 – COATINGS, PAINTS, AND LIQUID EPOXY
 619-B-314 ALTERNATE FINISH COAT FOR PARTIAL PAINT SYSTEM (PROPOSED TO DISCONTINUE)
 620-R-483 SOUND BARRIER SYSTEMS

Solvent cleaning in accordance with 619.08(a) shall be performed to remove all oils, soluble salts, visible grease, and any other surface contaminants before all other cleaning methods are started.

Field cleaned steel surfaces shall ~~be primed~~ receive a coat of primer the same day as cleaned, except for areas requiring a second abrasive blast cleaning. Those areas shall ~~be primed~~ receive a coat of primer the same day as the second cleaning. If rust forms after cleaning, the surface shall be cleaned again before ~~painting~~ coating. Work shall be stopped when there is disagreement about whether a surface has been adequately cleaned. Written notification shall be provided specifically identifying the problem.

Cleaning shall be scheduled so that dust or other contaminants do not fall on wet, newly ~~paint~~ coated surfaces.

A dust collector suitable for the containment type and size shall be used during all blast cleaning operations in preparation for all structural steel ~~paint~~ coating systems and as directed for a partial ~~paint~~ coating system.

On existing bridges when abrasive blast cleaning is used, clean dry media in accordance with SSPC-AB 1 or SSPC-AB 3 shall be used. The media shall produce a profile that is free of oil, soluble salts, greases, and other similar substances which can contaminate the blasted surface. If ferrous metallic media is chosen and the Contractor elects to recycle the media by running the media through recycling equipment, the recycling equipment shall be capable of separating the blasting media from the ~~paint~~ coating debris and the cleanliness of the recycled ferrous metallic media shall be in accordance with SSPC-AB 2.

SECTION 619, BEGIN LINE 436, DELETE AND INSERT AS FOLLOWS:

619.09 PaintCoating Systems

~~Paint systems~~ Every component of a coating system shall be from the same manufacturer and shall be compatible with each other. Coatings shall be applied in accordance with the manufacturer's recommendations. The dry film thickness of a ~~paint~~ coating will be measured with a calibrated film thickness gauge in accordance with SSPC

REVISION TO STANDARD SPECIFICATIONS AND SPECIAL PROVISIONS

SECTION 101 – DEFINITIONS AND TERMS
 SECTION 104 – SCOPE OF WORK
 SECTION 202 – REMOVAL OF STRUCTURES AND OBSTRUCTIONS
 SECTION 203 – EXCAVATION AND EMBANKMENT
 SECTION 604 – SIDEWALKS, CURB RAMPS, STEPS, AND HANDRAILS
 SECTION 619 – COATING BRIDGE STEEL
 SECTION 711 – STEEL STRUCTURES
 SECTION 712 – TIMBER STRUCTURES
 SECTION 729 – HEAT STRAIGHTENING OF STEEL MEMBERS IN THE FIELD
 SECTION 801 – TRAFFIC CONTROLS FOR CONSTRUCTION AND MAINTENANCE OPERATIONS
 SECTION 802 – SIGNS
 SECTION 805 – TRAFFIC SIGNALS
 SECTION 807 – HIGHWAY ILLUMINATION
 SECTION 909 – COATINGS, PAINTS, AND LIQUID EPOXY
 619-B-314 ALTERNATE FINISH COAT FOR PARTIAL PAINT SYSTEM (PROPOSED TO DISCONTINUE)
 620-R-483 SOUND BARRIER SYSTEMS

PA 2. All ~~paint~~ coatings shall have a dry film thickness not less than 80% of the required dry film thickness.

(a) Structural Steel ~~Paint~~Coating System

The coating system shall consist of an inorganic zinc primer with a dry film thickness of 3 mil, an epoxy intermediate coat with a dry film thickness of 4 mil, and a polyurethane finish coat with a dry film thickness of 3 mil for the ~~painting~~coating of steel bridges and other structural steel.

(b) Partial ~~Paint~~Coating System

The coating system shall consist of *an* organic zinc primer with a dry film thickness of 3 mil and a *finish coat with a dry film thickness of 3 mil. The finish coat shall be either a waterborne finish coat with a dry film thickness of 3 mil or a polyurethane finish coat for partial painting*coating of steel bridges and other structural steel *within the limits shown on the plans.*

619.10 ~~Painting~~Coating

~~Painting~~The application of all coatings shall be performed by a SSPC certified contractor, except as noted in 619.08.

Concrete at all junction points of concrete and steel shall be adequately shielded or otherwise protected so the application of ~~paint~~the coating on steel is full and complete, and that ~~spraying~~overspray or spatter onto the ~~nearby~~ concrete ~~or other surfaces~~ is minimized.

If a blasted or ~~paint~~ed coated surface is unsatisfactory, removal of the ~~paint~~coating, a thorough cleaning of the surface, and ~~repainting~~recoating or other correction will be required as directed. Where defects or damages occur in a film of any coating, all defective areas shall be removed to soundly bonded ~~paint~~coating or bare steel and ~~paint~~ed recoated to the specified thickness.

No lettering shall be ~~paint~~ed marked on bare or ~~paint~~ed coated steel surfaces, except marks required for erection and project information stenciled in accordance with 619.10(g).

Joints of all lapping members shall be caulked after either the application of the

REVISION TO STANDARD SPECIFICATIONS AND SPECIAL PROVISIONS

SECTION 101 – DEFINITIONS AND TERMS
SECTION 104 – SCOPE OF WORK
SECTION 202 – REMOVAL OF STRUCTURES AND OBSTRUCTIONS
SECTION 203 – EXCAVATION AND EMBANKMENT
SECTION 604 – SIDEWALKS, CURB RAMPS, STEPS, AND HANDRAILS
SECTION 619 – COATING BRIDGE STEEL
SECTION 711 – STEEL STRUCTURES
SECTION 712 – TIMBER STRUCTURES
SECTION 729 – HEAT STRAIGHTENING OF STEEL MEMBERS IN THE FIELD
SECTION 801 – TRAFFIC CONTROLS FOR CONSTRUCTION AND MAINTENANCE OPERATIONS
SECTION 802 – SIGNS
SECTION 805 – TRAFFIC SIGNALS
SECTION 807 – HIGHWAY ILLUMINATION
SECTION 909 – COATINGS, PAINTS, AND LIQUID EPOXY
619-B-314 ALTERNATE FINISH COAT FOR PARTIAL PAINT SYSTEM (PROPOSED TO DISCONTINUE)
620-R-483 SOUND BARRIER SYSTEMS

epoxy intermediate coat of the structural steel ~~paint~~coating system or the application of the organic zinc primer of the partial ~~paint~~coating system. The intermediate ~~coat~~ or primer ~~coat~~ shall be cured to the manufacturer's recommended coating cure time prior to caulking.

SECTION 619, BEGIN LINE 486, DELETE AND INSERT AS FOLLOWS:

(a) Weather Limitations

~~Field painting will~~Application of a coating in an uncontrolled environment shall not be ~~allowed~~performed between November 15 and the following April 1 unless the Contractor requests different date ranges are requested to work during this period in the QCP and it is approved in writing, provides an amended QCP, and written approval is received from the Engineer.

[moved to a separate paragraph] ~~Painting~~Coating application shall begin only when the 24 h ambient temperature is to remain above 50°F after ~~paint~~ application, and the steel surface temperature is between 50°F and 100°F unless different temperature ranges are requested in the QCP and approved in writing. Coating, ~~painting~~, and curing shall be done only when the relative humidity is to remain between 30% and 80%. The pot life and induction time shall be in accordance with the manufacturer's recommendations for the existing temperature and humidity.

~~Paint~~A coating shall not be applied when the air is misty, or when conditions are otherwise unsuitable. The surface temperature of the steel to be ~~paint~~coated shall not be within 5°F of the dew point. When ~~painting~~coating in a protected area to eliminate the above conditions, the steel shall remain under cover until the ~~paint~~coating is dry. All wet ~~paint~~or uncured coating which has been exposed to excessive humidity, rain, snow, or condensation shall be allowed to dry or cure. Damaged ~~paint~~coating shall then be removed. The surface shall be re-cleaned and ~~repainted~~recoated as directed. The Engineer will be the sole authority to decide when work may begin or shall stop due to weather conditions.

(b) Storage

~~Paint~~All coatings shall be stored in accordance with the manufacturer's recommendations. If ~~paint~~a coating is allowed to remain in storage, the containers shall be turned end for end at least once per week. The ~~paint~~coating shall be used within the manufacturer's recommended shelf life.

REVISION TO STANDARD SPECIFICATIONS AND SPECIAL PROVISIONS

SECTION 101 – DEFINITIONS AND TERMS
 SECTION 104 – SCOPE OF WORK
 SECTION 202 – REMOVAL OF STRUCTURES AND OBSTRUCTIONS
 SECTION 203 – EXCAVATION AND EMBANKMENT
 SECTION 604 – SIDEWALKS, CURB RAMPS, STEPS, AND HANDRAILS
 SECTION 619 – COATING BRIDGE STEEL
 SECTION 711 – STEEL STRUCTURES
 SECTION 712 – TIMBER STRUCTURES
 SECTION 729 – HEAT STRAIGHTENING OF STEEL MEMBERS IN THE FIELD
 SECTION 801 – TRAFFIC CONTROLS FOR CONSTRUCTION AND MAINTENANCE OPERATIONS
 SECTION 802 – SIGNS
 SECTION 805 – TRAFFIC SIGNALS
 SECTION 807 – HIGHWAY ILLUMINATION
 SECTION 909 – COATINGS, PAINTS, AND LIQUID EPOXY
 619-B-314 ALTERNATE FINISH COAT FOR PARTIAL PAINT SYSTEM (PROPOSED TO DISCONTINUE)
 620-R-483 SOUND BARRIER SYSTEMS

(c) Mixing

~~Paint~~All coatings shall be thoroughly mixed so that the pigment is completely in suspension and the consistency is uniform. Mechanical mixers shall be used in accordance with the manufacturer's instructions. The ~~paint~~coating shall remain in this condition during application to the steel surface. After initial mixing and before application, *inorganic and organic* zinc primer shall be strained through a metal screen not coarser than the No. 30 (600 µm) sieve.

Partially empty containers of ~~paint~~a coating shall not be used. Partial mixing of containers ~~will~~shall not be ~~allowed~~done. All ~~paint~~containers of a coating shall remain closed until needed for mixing.

(d) Thinning

When required for proper application, the ~~thinning of field paint~~addition of a *thinner to a coating* will be allowed. Only thinners recommended by the manufacturer and as approved shall be used. Thinners shall be added to ~~paint~~a coating in accordance with the manufacturer's recommendations. The maximum quantity added shall not exceed the manufacturer's recommendations. The thinned ~~paint~~coating shall not exceed IDEM regulations for volatile organic compounds.

The Contractor shall contact IDEM and the local air pollution control board for information about any volatile organic compound regulations or restrictions.

(e) Application of ~~Paint~~Coatings

All ~~paint~~coatings shall be of colors to produce a distinct contrast with adjacent coatings, including the color of a clean steel surface.

~~Paint~~Coatings shall be applied by either an airless or conventional spray method which has been recommended by the ~~paint~~coating manufacturer. ~~The e~~Compressed air used for ~~painting~~the application of a coating shall pass through an oil and water extractor before ~~entering the paint~~meeting the coating in the pot. However, areas to be ~~paint~~coated which are inaccessible to spray application or areas requiring touchup may be ~~paint~~coated with brush or daubers. Epoxy intermediate coatings and polyurethane finish

REVISION TO STANDARD SPECIFICATIONS AND SPECIAL PROVISIONS

SECTION 101 – DEFINITIONS AND TERMS
 SECTION 104 – SCOPE OF WORK
 SECTION 202 – REMOVAL OF STRUCTURES AND OBSTRUCTIONS
 SECTION 203 – EXCAVATION AND EMBANKMENT
 SECTION 604 – SIDEWALKS, CURB RAMPS, STEPS, AND HANDRAILS
 SECTION 619 – COATING BRIDGE STEEL
 SECTION 711 – STEEL STRUCTURES
 SECTION 712 – TIMBER STRUCTURES
 SECTION 729 – HEAT STRAIGHTENING OF STEEL MEMBERS IN THE FIELD
 SECTION 801 – TRAFFIC CONTROLS FOR CONSTRUCTION AND MAINTENANCE OPERATIONS
 SECTION 802 – SIGNS
 SECTION 805 – TRAFFIC SIGNALS
 SECTION 807 – HIGHWAY ILLUMINATION
 SECTION 909 – COATINGS, PAINTS, AND LIQUID EPOXY
 619-B-314 ALTERNATE FINISH COAT FOR PARTIAL PAINT SYSTEM (PROPOSED TO DISCONTINUE)
 620-R-483 SOUND BARRIER SYSTEMS

~~paints~~ ~~coatings~~ may also be applied by brushes or rollers provided the coating cures to a smooth and uniform finish. Spray shall be adjusted to produce a uniform coating.

1. Stripe Coat

If using the structural steel ~~paint~~ ~~coating~~ system in accordance with 619.09(a), a stripe coat in accordance with SSPC-PA Guide 11 shall be applied. All sharp edges, welds, outside corners, bolt heads, nuts, threads, crevices, plate seams, back-to-back angle seams, pitted steel, rivet heads, and other sharp discontinuities shall be striped on the second and third coats, and then ~~repainted~~ ~~recoated~~ with the remaining steel surfaces. Striping shall extend at least 1 in. from edges. If specified, the stripe coat shall be allowed to dry to the manufacturer's recommended recoat dry time prior to ~~painting~~ ~~applying~~ the second and third coats on the remaining steel surfaces.

If using the partial ~~paint~~ ~~coating~~ system in accordance with 619.09(b), a stripe coat in accordance with SSPC-PA Guide 11 shall be applied. All sharp edges, welds, outside corners, bolt heads, nuts, threads, crevices, plate seams, back-to-back angle seams, pitted steel, rivet heads, and other sharp discontinuities shall be striped on each of the ~~two~~ coats, and then ~~repainted~~ ~~recoated~~ with the remaining steel surfaces. Striping shall extend at least 1 in. from edges. If specified, the stripe coat shall be allowed to dry to the manufacturer's recommended recoat dry time prior to ~~painting~~ ~~coating~~ the remaining steel surfaces. ~~Painting~~ ~~Coating application~~ techniques shall minimize ~~dry~~ ~~overspray~~ ~~or~~ ~~spatter~~. Dry overspray ~~and~~ ~~spatter~~ shall be removed prior to application of other coatings and after application of the finish coat.

For both ~~paint~~ ~~coating~~ systems, the stripe coat may be applied with either a brush or a sprayer. If the Contractor-chosen method of applying the stripe coat is not producing results acceptable to the Engineer, the Engineer will require the stripe coat application method to be changed.

SECTION 619, BEGIN LINE 582, DELETE ~~AND INSERT~~ AS FOLLOWS:

The curing time of all other ~~paint systems or~~ coatings shall be in accordance with the manufacturer's recommendations.

SECTION 619, BEGIN LINE 597, DELETE AND INSERT AS FOLLOWS:

REVISION TO STANDARD SPECIFICATIONS AND SPECIAL PROVISIONS

SECTION 101 – DEFINITIONS AND TERMS
 SECTION 104 – SCOPE OF WORK
 SECTION 202 – REMOVAL OF STRUCTURES AND OBSTRUCTIONS
 SECTION 203 – EXCAVATION AND EMBANKMENT
 SECTION 604 – SIDEWALKS, CURB RAMPS, STEPS, AND HANDRAILS
 SECTION 619 – COATING BRIDGE STEEL
 SECTION 711 – STEEL STRUCTURES
 SECTION 712 – TIMBER STRUCTURES
 SECTION 729 – HEAT STRAIGHTENING OF STEEL MEMBERS IN THE FIELD
 SECTION 801 – TRAFFIC CONTROLS FOR CONSTRUCTION AND MAINTENANCE OPERATIONS
 SECTION 802 – SIGNS
 SECTION 805 – TRAFFIC SIGNALS
 SECTION 807 – HIGHWAY ILLUMINATION
 SECTION 909 – COATINGS, PAINTS, AND LIQUID EPOXY
 619-B-314 ALTERNATE FINISH COAT FOR PARTIAL PAINT SYSTEM (PROPOSED TO DISCONTINUE)
 620-R-483 SOUND BARRIER SYSTEMS

619.11 Shop-Application of a Coat of Primer Coating for New Steel

The shop performing the cleaning and the application of the ~~prime-coat of primer~~ for new structural steel shall have a valid AISC-420-10/SSPC-QP 3 certification. Abrasive used for cleaning steel in the shop shall be an abrasive that produces a surface profile in accordance with 619.08. *The Contractor shall coordinate with the steel fabrication shop and the Contractor applying the remaining coatings after steel erection to ensure the shop-applied primer and the remaining field-applied coats of the coating system are all from the same manufacturer. Mixing primer and coating products from different manufacturers shall will not be done allowed.* The inorganic zinc primer ~~coat~~ shall be applied to all structural steel in the shop. The remaining two coats of the structural steel coating system shall be applied in the field after final erection. A structural steel ~~paint~~ coating system in accordance with 619.09(a) shall be used. When shear connectors have been specified, the top of the top flange shall not be primed. Erection marks may be painted on ~~zinc painted zinc-coated~~ surfaces. Machine finished surfaces for sliding contact shall be coated with heavy grease as soon as practicable after being accepted, but before removal from the shop.

Shop primed beams shall not be loaded for shipment until the primer has been allowed to cure for a minimum of 48 h.

(a) Non-Weathering Steel

All structural steel shall be cleaned in accordance with 619.08(e).

All structural steel shall receive an inorganic zinc primer, including faying surfaces of high strength bolted connections and areas in contact with concrete. Surfaces, other than the contact surfaces described above, which are inaccessible after erection shall be ~~painted~~ coated in the shop with the full ~~paint~~ coating system required on the completed bridge.

(b) Weathering Steel

All structural steel shall be left ~~unpainted~~ uncoated, except as shown on the plans. All diaphragms, stiffeners, and other appurtenances located within the limits shown on the plans shall be included in the ~~painting~~ area to be coated. Surfaces to be ~~painted~~ coated shall be cleaned in accordance with 619.08(e). Surfaces shall be ~~painted~~ coated in accordance

REVISION TO STANDARD SPECIFICATIONS AND SPECIAL PROVISIONS

SECTION 101 – DEFINITIONS AND TERMS
 SECTION 104 – SCOPE OF WORK
 SECTION 202 – REMOVAL OF STRUCTURES AND OBSTRUCTIONS
 SECTION 203 – EXCAVATION AND EMBANKMENT
 SECTION 604 – SIDEWALKS, CURB RAMPS, STEPS, AND HANDRAILS
 SECTION 619 – COATING BRIDGE STEEL
 SECTION 711 – STEEL STRUCTURES
 SECTION 712 – TIMBER STRUCTURES
 SECTION 729 – HEAT STRAIGHTENING OF STEEL MEMBERS IN THE FIELD
 SECTION 801 – TRAFFIC CONTROLS FOR CONSTRUCTION AND MAINTENANCE OPERATIONS
 SECTION 802 – SIGNS
 SECTION 805 – TRAFFIC SIGNALS
 SECTION 807 – HIGHWAY ILLUMINATION
 SECTION 909 – COATINGS, PAINTS, AND LIQUID EPOXY
 619-B-314 ALTERNATE FINISH COAT FOR PARTIAL PAINT SYSTEM (PROPOSED TO DISCONTINUE)
 620-R-483 SOUND BARRIER SYSTEMS

with 619.09(a), except the finish coat shall be in accordance with 909.02(e). *The field-applied finish coat for weathering steel will be allowed to be furnished from a different manufacturer than the manufacturer that furnished the primer and epoxy intermediate coat.*

619.12 Field ~~Painting~~Coating New Steel Bridge

All structural steel surfaces which are accessible after final erection shall be ~~paint~~~~ed~~coated with the remaining coatings specified for ~~the~~ structural steel ~~paint~~coating system in accordance with 619.09(a) in the field after final erection.

Portions of new structural steel, including cross frames, diaphragms, stiffeners, and all other appurtenances located within the limits of concrete end bent encasement as shown on the plans, will only require the inorganic zinc primer-coat.

Surface areas where the inorganic zinc primer was damaged during shipping, handling, and erection shall be cleaned in accordance with 619.08(a) and either 619.08(d) or 619.08(i). Likewise, all bolt and field connections shall be cleaned in the same manner. All the damaged areas, and bolt and field connections shall then be ~~paint~~edcoated with the ~~same manufacturer's~~ inorganic zinc primer ~~that was~~ applied in the shop. This requirement will not apply to temporary steel bridges.

Where steel surfaces have been ~~paint~~edcoated with the ~~full paint~~ structural steel ~~coating~~ system and the ~~paint~~ coatings have been damaged, the affected steel surface areas shall be cleaned in accordance with 619.08(i). ~~S~~The structural steel ~~paint~~coating system shall then be re-applied.

For weathering steel girders, caulk shall be applied to act as a drip bead as shown on the plans.

619.13 ~~Painting~~Coating Existing Steel Bridges

The surfaces to be cleaned and ~~paint~~edcoated shall include the surfaces of all steel members of the superstructure, substructure, floor beams, stringers, plates, castings, bearing assemblies, ornamental handrails, lattice work, and other steel appurtenances. When shear connectors have been specified, the top of the top flange shall not be

REVISION TO STANDARD SPECIFICATIONS AND SPECIAL PROVISIONS

SECTION 101 – DEFINITIONS AND TERMS
SECTION 104 – SCOPE OF WORK
SECTION 202 – REMOVAL OF STRUCTURES AND OBSTRUCTIONS
SECTION 203 – EXCAVATION AND EMBANKMENT
SECTION 604 – SIDEWALKS, CURB RAMPS, STEPS, AND HANDRAILS
SECTION 619 – COATING BRIDGE STEEL
SECTION 711 – STEEL STRUCTURES
SECTION 712 – TIMBER STRUCTURES
SECTION 729 – HEAT STRAIGHTENING OF STEEL MEMBERS IN THE FIELD
SECTION 801 – TRAFFIC CONTROLS FOR CONSTRUCTION AND MAINTENANCE OPERATIONS
SECTION 802 – SIGNS
SECTION 805 – TRAFFIC SIGNALS
SECTION 807 – HIGHWAY ILLUMINATION
SECTION 909 – COATINGS, PAINTS, AND LIQUID EPOXY
619-B-314 ALTERNATE FINISH COAT FOR PARTIAL PAINT SYSTEM (PROPOSED TO DISCONTINUE)
620-R-483 SOUND BARRIER SYSTEMS

~~paint~~coated.

If the contract specifies clean steel bridge, the bridge steel shall be cleaned in accordance with 619.08(a) and either 619.08(e) or 619.08(i). The structural steel ~~paint~~coating system in accordance with 619.09(a) shall be used for ~~painting~~coating.

If the contract specifies clean steel bridge, partial, the bridge steel shall be cleaned in accordance with 619.08(a) and either 619.08(e), or 619.08(h). The partial ~~paint~~coating system in accordance with 619.09(b) shall be then used for ~~painting~~coating.

When the plans show encasing the ends of existing structural steel members in concrete, all beams and girders, cross frames, diaphragms, stiffeners, and all other appurtenances located within the limits of the partial ~~painting~~coating zone as shown on the plans shall be cleaned in accordance with 619.08(a) and either 619.08(e) or 619.08(h) and shall receive the partial ~~paint~~coating system in accordance with 619.09(b). If the contract also includes pay items for clean steel bridge and ~~paint~~coat steel bridge, all exposed structural steel shall be cleaned in accordance with 619.08(a) and either 619.08(e) or 619.08(i), and ~~paint~~coated in accordance with 619.09(a), from the face of concrete encasement to opposite face of concrete encasement.

SECTION 619, BEGIN LINE 692, DELETE AND INSERT AS FOLLOWS:

The roadway drain castings shall be ~~paint~~coated with a black ~~polyurethane~~ finish coat in accordance with 909.02(c).

If a roadway drain casting extension pipe is damaged or missing, it shall be replaced. The extension pipe shall be in accordance with 715.

619.16 Clean and ~~Paint~~Coat Bearing Assemblies and Steel Piling

(a) Bearing Assemblies

When shown on the plans or a pay item is included in the schedule of pay items, all bearing assemblies including top and bottom plates of each assembly shall be cleaned in accordance with 619.08(a) and 619.08(d). Pollution control shall be in accordance with 619.07.

REVISION TO STANDARD SPECIFICATIONS AND SPECIAL PROVISIONS

SECTION 101 – DEFINITIONS AND TERMS
 SECTION 104 – SCOPE OF WORK
 SECTION 202 – REMOVAL OF STRUCTURES AND OBSTRUCTIONS
 SECTION 203 – EXCAVATION AND EMBANKMENT
 SECTION 604 – SIDEWALKS, CURB RAMPS, STEPS, AND HANDRAILS
 SECTION 619 – COATING BRIDGE STEEL
 SECTION 711 – STEEL STRUCTURES
 SECTION 712 – TIMBER STRUCTURES
 SECTION 729 – HEAT STRAIGHTENING OF STEEL MEMBERS IN THE FIELD
 SECTION 801 – TRAFFIC CONTROLS FOR CONSTRUCTION AND MAINTENANCE OPERATIONS
 SECTION 802 – SIGNS
 SECTION 805 – TRAFFIC SIGNALS
 SECTION 807 – HIGHWAY ILLUMINATION
 SECTION 909 – COATINGS, PAINTS, AND LIQUID EPOXY
 619-B-314 ALTERNATE FINISH COAT FOR PARTIAL PAINT SYSTEM (PROPOSED TO DISCONTINUE)
 620-R-483 SOUND BARRIER SYSTEMS

If the pay item clean and ~~paint~~ ~~coat~~ bearing assemblies is listed in the schedule of pay items for a particular structure, the entire bearing assembly shall be ~~paint~~ ~~coated~~ with the structural steel ~~paint~~ ~~coating~~ system in accordance with 619.09(a).

If the pay item, ~~paint~~ ~~coat~~ steel bridge, or ~~paint~~ ~~coat~~ steel bridge, partial, is listed in the schedule of pay items for a particular structure, the entire bearing assembly shall be ~~paint~~ ~~coated~~ with the structural steel ~~paint~~ ~~coating~~ system that is being used on the rest of the bridge.

619.16.1(b) Clean and Paint Coat Steel Piling

All exposed steel piling shall be cleaned in accordance with 619.08(a) and either 619.08(e) or 619.08(i). The structural steel ~~paint~~ ~~coating~~ system in accordance with 619.09(a) shall be applied. The color of the ~~top~~ ~~finish~~ coat shall be SAE-AMS-STD-595, color No. 13711.

619.17 Responsibility for Damage

Unless otherwise specified by the Engineer in writing, full containment shall be provided when performing the surface preparation operation and when applying all ~~coats~~ ~~of~~ ~~paint~~ ~~coatings~~, except primer-~~coats~~, with spray equipment. All persons and property shall be protected from damage or injury from the surface preparation operations and ~~painting~~ ~~coating~~ operations by providing containment as described in the QCP. Persons and property shall include, but not be limited to, pedestrians, vehicles, and other traffic upon or underneath a bridge, all portions of the bridge superstructure and substructure, and all adjacent property. *When applying a primer or coating using means other than spray equipment, all persons and property shall be protected from damage or injury. The means and extent of the protection shall be as described in the QCP.* The Contractor shall be responsible for damages in accordance with 107.17.

SECTION 619, BEGIN LINE 746, DELETE AND INSERT AS FOLLOWS:

619.19 Method of Measurement

Cleaning and ~~painting~~ ~~coating~~ of steel structural members, cleaning the top of the top flange of steel structural members, cleaning and ~~painting~~ ~~coating~~ of bearing assemblies, and cleaning and ~~painting~~ ~~coating~~ of steel piling will not be measured for payment.

REVISION TO STANDARD SPECIFICATIONS AND SPECIAL PROVISIONS

SECTION 101 – DEFINITIONS AND TERMS
 SECTION 104 – SCOPE OF WORK
 SECTION 202 – REMOVAL OF STRUCTURES AND OBSTRUCTIONS
 SECTION 203 – EXCAVATION AND EMBANKMENT
 SECTION 604 – SIDEWALKS, CURB RAMPS, STEPS, AND HANDRAILS
 SECTION 619 – COATING BRIDGE STEEL
 SECTION 711 – STEEL STRUCTURES
 SECTION 712 – TIMBER STRUCTURES
 SECTION 729 – HEAT STRAIGHTENING OF STEEL MEMBERS IN THE FIELD
 SECTION 801 – TRAFFIC CONTROLS FOR CONSTRUCTION AND MAINTENANCE OPERATIONS
 SECTION 802 – SIGNS
 SECTION 805 – TRAFFIC SIGNALS
 SECTION 807 – HIGHWAY ILLUMINATION
 SECTION 909 – COATINGS, PAINTS, AND LIQUID EPOXY
 619-B-314 ALTERNATE FINISH COAT FOR PARTIAL PAINT SYSTEM (PROPOSED TO DISCONTINUE)
 620-R-483 SOUND BARRIER SYSTEMS

Cleaning areas around bridge joints and other areas with visible corrosion pitting a second time will not be measured for payment. Disposal of the waste generated by the cleaning operation will not be measured for payment.

Cleaning roadway drain castings, caulking joints of lapping members, and caulking on weathering steel will not be measured for payment.

For steel that will become the property of the Contractor, cleaning existing steel, removal of mill scale, testing, disposal of the waste, containment, and all other items involved with this work will not be measured as per 202.13.

If a structure is shown in the contract documents as being built before 1995, no measurement will be made of the area covered by mill scale. Otherwise, the area of structural steel covered by mill scale will be measured for payment after a proper cleaning of the entire containment area or an agreed large portion thereof and removing all other existing materials, including all paint, coatings and rust. The percentage of the area of structural steel covered by existing mill scale will be representative of this entire area. The pre-established remedies for this changed condition apply in accordance with 104.02(d) and 619.20.

Roadway drain casting extension pipe will be measured in accordance with 715.13.

The estimated weight, length, number of steel spans, surface area of steel, and type of primer shown on the plans or in the Proposal is incidental information. Such information is approximate only. The Department will not guarantee its accuracy.

619.20 Basis of Payment

Existing steel bridges to be cleaned, or partially cleaned, whichever is specified, will be paid for at the contract lump sum price for clean steel bridge or clean steel bridge, partial, at the bridge number specified. Cleaning the top of the top flange of existing steel bridges will be paid for at the contract lump sum price for clean steel bridge, top flanges, at the bridge number specified. Existing steel bridges to be ~~paint~~*coated*, or partially ~~paint~~*coated*, whichever is specified, will be paid for at the contract lump sum price for ~~paint~~*coat* steel bridge or ~~paint~~*coat* steel bridge, partial, at the bridge number specified.

REVISION TO STANDARD SPECIFICATIONS AND SPECIAL PROVISIONS

- SECTION 101 – DEFINITIONS AND TERMS
- SECTION 104 – SCOPE OF WORK
- SECTION 202 – REMOVAL OF STRUCTURES AND OBSTRUCTIONS
- SECTION 203 – EXCAVATION AND EMBANKMENT
- SECTION 604 – SIDEWALKS, CURB RAMPS, STEPS, AND HANDRAILS
- SECTION 619 – COATING BRIDGE STEEL
- SECTION 711 – STEEL STRUCTURES
- SECTION 712 – TIMBER STRUCTURES
- SECTION 729 – HEAT STRAIGHTENING OF STEEL MEMBERS IN THE FIELD
- SECTION 801 – TRAFFIC CONTROLS FOR CONSTRUCTION AND MAINTENANCE OPERATIONS
- SECTION 802 – SIGNS
- SECTION 805 – TRAFFIC SIGNALS
- SECTION 807 – HIGHWAY ILLUMINATION
- SECTION 909 – COATINGS, PAINTS, AND LIQUID EPOXY
- 619-B-314 ALTERNATE FINISH COAT FOR PARTIAL PAINT SYSTEM (PROPOSED TO DISCONTINUE)
- 620-R-483 SOUND BARRIER SYSTEMS

When specified as a separate pay item in the contract, cleaning and ~~painting~~ ~~coating~~ bearing assemblies will be paid for at the contract lump sum price for clean and ~~paint~~ ~~coat~~ bearing assemblies, at the bridge number specified.

When specified as a separate pay item in the contract, cleaning and ~~painting~~ ~~coating~~ steel piling will be paid for at the contract lump sum price for clean and ~~paint~~ ~~coat~~ steel piling, at the bridge number specified.

SECTION 619, BEGIN LINE 830, DELETE AND INSERT AS FOLLOWS:

The price for the clean steel bridge item, per bridge, used in all pre-established remedies to changed conditions referenced in this section will be limited to the lesser of the following:

1. 70% of the sum of the clean steel bridge item and ~~paint~~ ~~coat~~ steel bridge item for that bridge; or
2. the actual amount for the clean steel bridge item for that bridge shown in the Schedule of Pay Items.

SECTION 619, BEGIN LINE 841, INSERT AS FOLLOWS:

For steel that will become the property of the Contractor, payment for cleaning existing steel, removal of mill scale, testing, disposal of the waste, containment, and all other costs involved *in* this work will be in accordance with 202.14.

SECTION 619, BEGIN LINE 850, DELETE AND INSERT AS FOLLOWS:

Payment will be made under:

Pay Item	Pay Unit Symbol
Clean and Paint Coat Bearing Assemblies, Br. No. ____	LS
Clean and Paint Coat Steel Piling, Br. No. ____	LS
Clean Steel Bridge, Partial, QP- ____, Br. No. ____	LS
Clean Steel Bridge, QP- ____, Br. No. ____	LS
Clean Steel Bridge, Top Flanges, QP-2, Br. No. ____	LS

REVISION TO STANDARD SPECIFICATIONS AND SPECIAL PROVISIONS

- SECTION 101 – DEFINITIONS AND TERMS
- SECTION 104 – SCOPE OF WORK
- SECTION 202 – REMOVAL OF STRUCTURES AND OBSTRUCTIONS
- SECTION 203 – EXCAVATION AND EMBANKMENT
- SECTION 604 – SIDEWALKS, CURB RAMPS, STEPS, AND HANDRAILS
- SECTION 619 – COATING BRIDGE STEEL
- SECTION 711 – STEEL STRUCTURES
- SECTION 712 – TIMBER STRUCTURES
- SECTION 729 – HEAT STRAIGHTENING OF STEEL MEMBERS IN THE FIELD
- SECTION 801 – TRAFFIC CONTROLS FOR CONSTRUCTION AND MAINTENANCE OPERATIONS
- SECTION 802 – SIGNS
- SECTION 805 – TRAFFIC SIGNALS
- SECTION 807 – HIGHWAY ILLUMINATION
- SECTION 909 – COATINGS, PAINTS, AND LIQUID EPOXY
- 619-B-314 ALTERNATE FINISH COAT FOR PARTIAL PAINT SYSTEM (PROPOSED TO DISCONTINUE)
- 620-R-483 SOUND BARRIER SYSTEMS

Coat Steel Bridge, Br. No.	LS
Coat Steel Bridge, Partial, Br. No.	LS
Disposal of Cleaning Waste, _____, Br. No. _____	LS
waste type	
Paint Coat Steel Bridge, Br. No.	LS
Paint Coat Steel Bridge, Partial, Br. No.	LS

The cost to prepare a QCP shall be included in the cost of the pay items of this section. The cost of providing the Department with access to the bridge and seasonal or weather limitations shall be included in the cost of the pay items of this section.

If a structure is shown in the contract documents as being built before 1995, no additional payment will be made for the removal of mill scale. The cost of the removal of mill scale shall be included in the cost of clean steel bridge, clean steel bridge, partial, clean and ~~paint~~coat bearing assemblies, clean and ~~paint~~coat steel piling, or clean steel bridge, top flanges.

SECTION 619, BEGIN LINE 881, DELETE AND INSERT AS FOLLOWS:

The cost of furnishing all materials, equipment, and labor required for solvent cleaning, scraping, steel brushing, or other acceptable methods for removing ~~paint~~coatings in the locations directed shall be included in the cost of clean steel bridge, clean steel bridge, partial, clean and ~~paint~~coat bearing assemblies, clean and ~~paint~~coat steel piling, or clean steel bridge, top flanges. The cost of cleaning roadway drain castings shall be included in the cost of clean steel bridge or clean steel bridge, partial.

The cost of providing containment in accordance with 619.07 and 619.17 and personal protective equipment shall be included in the cost of the pay items of this section.

The cost of furnishing all materials, equipment, and labor required to perform the quality control tasks outlined in 619.03 shall be included in the cost of clean steel bridge or clean steel bridge, partial, clean and ~~paint~~coat bearing assemblies, clean and ~~paint~~coat steel piling, or clean steel bridge, top flanges.

REVISION TO STANDARD SPECIFICATIONS AND SPECIAL PROVISIONS

SECTION 101 – DEFINITIONS AND TERMS

SECTION 104 – SCOPE OF WORK

SECTION 202 – REMOVAL OF STRUCTURES AND OBSTRUCTIONS

SECTION 203 – EXCAVATION AND EMBANKMENT

SECTION 604 – SIDEWALKS, CURB RAMPS, STEPS, AND HANDRAILS

SECTION 619 – COATING BRIDGE STEEL

SECTION 711 – STEEL STRUCTURES

SECTION 712 – TIMBER STRUCTURES

SECTION 729 – HEAT STRAIGHTENING OF STEEL MEMBERS IN THE FIELD

SECTION 801 – TRAFFIC CONTROLS FOR CONSTRUCTION AND MAINTENANCE OPERATIONS

SECTION 802 – SIGNS

SECTION 805 – TRAFFIC SIGNALS

SECTION 807 – HIGHWAY ILLUMINATION

SECTION 909 – COATINGS, PAINTS, AND LIQUID EPOXY

619-B-314 ALTERNATE FINISH COAT FOR PARTIAL PAINT SYSTEM (PROPOSED TO DISCONTINUE)

620-R-483 SOUND BARRIER SYSTEMS

The cost of furnishing all materials including caulk, equipment, and labor to perform caulking and ~~painting~~ coating, including the stripe coats, with the structural steel ~~paint~~ coating system or the partial ~~paint~~ coating system shall be included in the cost of ~~paint~~ coat steel bridge or ~~paint~~ coat steel bridge, partial. The cost of switching stripe coat application methods shall be included in the cost of ~~paint~~ coat steel bridge or ~~paint~~ coat steel bridge, partial. The cost of furnishing all materials, equipment, and labor to perform ~~painting~~ coating of the roadway drain castings shall be included in the cost of ~~paint~~ coat steel bridge or ~~paint~~ coat steel bridge, partial.

The cost of all equipment, material, labor, testing, use of special cleaning methods, and shipping of waste stream samples shall be included in the cost of the clean steel bridge or clean steel bridge, partial, clean and ~~paint~~ coat bearing assemblies, clean and ~~paint~~ coat steel piling, or clean steel bridge, top flanges, pay items.

The cost of dust removal, wetting, and within the cross-sectional area measuring 5 ft longitudinally on both sides of a bridge deck joint as well as all areas of visible corrosion pitting, a second time shall be included in the clean steel bridge, clean steel bridge, partial, clean and ~~paint~~ coat bearing assemblies, or clean steel bridge, top flanges, pay items.

When a pay item is included in the schedule of pay items for clean and ~~paint~~ coat bearing assemblies, all costs associated with cleaning and ~~painting~~ coating bearing assemblies, except disposal of cleaning waste, shall be included in the cost of the pay item. If clean steel bridge, clean steel bridge, partial, ~~paint~~ coat steel bridge, or ~~paint~~ coat steel bridge, partial, are included as pay items in the schedule of pay items, no separate payment will be made for cleaning and ~~painting~~ coating bearing assemblies on that bridge number. The cost of cleaning and ~~painting~~ coating bearing assemblies shall be included in the cost of the respective clean steel bridge, clean steel bridge, partial, ~~paint~~ coat steel bridge, or ~~paint~~ coat steel bridge, partial, pay items for that bridge number.

When a pay item is included in the schedule of pay items for clean and ~~paint~~ coat steel piling, all costs associated with cleaning and ~~painting~~ coating steel piling, except disposal of cleaning waste, shall be included in the cost of the pay item.

REVISION TO STANDARD SPECIFICATIONS AND SPECIAL PROVISIONS

SECTION 101 – DEFINITIONS AND TERMS

SECTION 104 – SCOPE OF WORK

SECTION 202 – REMOVAL OF STRUCTURES AND OBSTRUCTIONS

SECTION 203 – EXCAVATION AND EMBANKMENT

SECTION 604 – SIDEWALKS, CURB RAMPS, STEPS, AND HANDRAILS

SECTION 619 – COATING BRIDGE STEEL

SECTION 711 – STEEL STRUCTURES

SECTION 712 – TIMBER STRUCTURES

SECTION 729 – HEAT STRAIGHTENING OF STEEL MEMBERS IN THE FIELD

SECTION 801 – TRAFFIC CONTROLS FOR CONSTRUCTION AND MAINTENANCE OPERATIONS

SECTION 802 – SIGNS

SECTION 805 – TRAFFIC SIGNALS

SECTION 807 – HIGHWAY ILLUMINATION

SECTION 909 – COATINGS, PAINTS, AND LIQUID EPOXY

619-B-314 ALTERNATE FINISH COAT FOR PARTIAL PAINT SYSTEM (PROPOSED TO DISCONTINUE)

620-R-483 SOUND BARRIER SYSTEMS

When encasing the ends of existing structural steel members in concrete is shown on the plans, all costs associated with cleaning and ~~painting~~ ~~coating~~ all structural steel within the limits of the partial ~~painting~~ ~~coating~~ zone, including but not limited to, equipment, material, labor, testing, use of special cleaning methods, and shipping of waste stream samples, shall be included in the cost of clean steel bridge, partial, and ~~paint~~ ~~coat~~ steel bridge, partial, pay items. If the contract also includes pay items for clean steel bridge and ~~paint~~ ~~coat~~ steel bridge, all costs associated with cleaning and ~~painting~~ ~~coating~~ all exposed structural steel, including but not limited to, equipment, material, labor, testing, use of special cleaning methods, and shipping of waste stream samples, shall be included in the cost of clean steel bridge and ~~paint~~ ~~coat~~ steel bridge pay items.

SECTION 711, BEGIN LINE 440, DELETE AND INSERT AS FOLLOWS:

711.31 Peening Welds by Means of Ultrasonic Impact Treatment, UIT

This work shall consist of removing existing paint ~~and coatings~~, repairing existing cracked welds, peening existing and repaired welds, and ~~painting~~ ~~coating~~ in accordance with 105.03.

SECTION 711, BEGIN LINE 460, DELETE AND INSERT AS FOLLOWS:

Paint ~~and coating~~ removal shall be in accordance with 619.08(a) and 619.08(i). ~~Painting~~ ~~Coating~~ shall be in accordance with 619.09 and 619.10.

SECTION 711, BEGIN LINE 770, DELETE AND INSERT AS FOLLOWS:

711.47 Shop Cleaning and ~~Painting~~ ~~Coating~~

Shop cleaning and ~~painting~~ ~~coating~~ shall be in accordance with applicable requirements of 619.

SECTION 711, BEGIN LINE 1142, DELETE AND INSERT AS FOLLOWS:

711.71 ~~Painting~~ ~~Coating~~

After erection is complete, the structure shall be ~~paint~~ ~~coated~~ unless otherwise provided. ~~Painting~~ ~~Coating~~ shall be in accordance with the applicable requirements of 619.

SECTION 711, BEGIN LINE 1269, DELETE AND INSERT AS FOLLOWS:

The cost of paint ~~and coating~~ removal, ~~painting~~ ~~coating~~, non-destructive testing, equipment, labor, materials, access, permits, and necessary incidentals shall be included in the cost of peening weld, UIT.

REVISION TO STANDARD SPECIFICATIONS AND SPECIAL PROVISIONS

- SECTION 101 – DEFINITIONS AND TERMS
- SECTION 104 – SCOPE OF WORK
- SECTION 202 – REMOVAL OF STRUCTURES AND OBSTRUCTIONS
- SECTION 203 – EXCAVATION AND EMBANKMENT
- SECTION 604 – SIDEWALKS, CURB RAMPS, STEPS, AND HANDRAILS
- SECTION 619 – COATING BRIDGE STEEL
- SECTION 711 – STEEL STRUCTURES
- SECTION 712 – TIMBER STRUCTURES
- SECTION 729 – HEAT STRAIGHTENING OF STEEL MEMBERS IN THE FIELD
- SECTION 801 – TRAFFIC CONTROLS FOR CONSTRUCTION AND MAINTENANCE OPERATIONS
- SECTION 802 – SIGNS
- SECTION 805 – TRAFFIC SIGNALS
- SECTION 807 – HIGHWAY ILLUMINATION
- SECTION 909 – COATINGS, PAINTS, AND LIQUID EPOXY
- 619-B-314 ALTERNATE FINISH COAT FOR PARTIAL PAINT SYSTEM (PROPOSED TO DISCONTINUE)
- 620-R-483 SOUND BARRIER SYSTEMS

SECTION 712, BEGIN LINE 10, DELETE AND INSERT AS FOLLOWS:

712.02 Materials

Materials shall be in accordance with the following:

Iron Castings	910.05(b)
Lumber and Timber (Treated).....	911.02
Lumber and Timber (Untreated).....	911.01
Malleable Iron Castings	910.05(d)
Preservatives	911.02(h)
Steel Castings	910.05(a)
Structural Steel.....	910.02
Waterborne Finish Paint Coat.....	909.02(d)

SECTION 712, BEGIN LINE 136, DELETE AND INSERT AS FOLLOWS:

712.08 ~~Painting~~Coating

~~Paint~~A coating shall be applied to untreated lumber and timber as shown on the plans or as otherwise specified. Lumber or timber treated with preservative shall not be ~~paint~~coated, unless otherwise specified. The color shall be as specified.

Surface preparation shall be the removal of all contamination such as oil, grease, dirt, foreign matter, rust, mold, mildew, and sealers. Knots and pitch streaks shall be scraped or burned, and sanded. All nail holes or small openings shall be caulked with a general purpose caulking compound.

The surfaces shall be ~~paint~~coated with one coat of waterborne finish ~~paint~~coating. The ~~paint~~coating shall be applied by brush or roller only and at the rate recommended by the manufacturer. All finishes shall be uniform in texture and color. If a ~~paint~~coated surface is unsatisfactory, the ~~paint~~coating shall be removed and the surface shall be cleaned and ~~repaint~~recoated or corrected as may be directed.

At the end of each work day, ~~paint~~ stains and splatters shall be removed from all surfaces not intended to receive the ~~paint~~coating applied for that day.

REVISION TO STANDARD SPECIFICATIONS AND SPECIAL PROVISIONS

- SECTION 101 – DEFINITIONS AND TERMS
- SECTION 104 – SCOPE OF WORK
- SECTION 202 – REMOVAL OF STRUCTURES AND OBSTRUCTIONS
- SECTION 203 – EXCAVATION AND EMBANKMENT
- SECTION 604 – SIDEWALKS, CURB RAMPS, STEPS, AND HANDRAILS
- SECTION 619 – COATING BRIDGE STEEL
- SECTION 711 – STEEL STRUCTURES
- SECTION 712 – TIMBER STRUCTURES
- SECTION 729 – HEAT STRAIGHTENING OF STEEL MEMBERS IN THE FIELD
- SECTION 801 – TRAFFIC CONTROLS FOR CONSTRUCTION AND MAINTENANCE OPERATIONS
- SECTION 802 – SIGNS
- SECTION 805 – TRAFFIC SIGNALS
- SECTION 807 – HIGHWAY ILLUMINATION
- SECTION 909 – COATINGS, PAINTS, AND LIQUID EPOXY
- 619-B-314 ALTERNATE FINISH COAT FOR PARTIAL PAINT SYSTEM (PROPOSED TO DISCONTINUE)
- 620-R-483 SOUND BARRIER SYSTEMS

SECTION 729, BEGIN LINE 17, DELETE AND INSERT AS FOLLOWS:

729.03 Materials

Materials shall be in accordance with the following:

Organic Zinc Primer.....	909.02(a)2
Partial Paint Coating System	619.09(b)
Structural Steel	910.02

CONSTRUCTION REQUIREMENTS

729.04 Pre-Heat Straightening Inspection

Steel members shall be inspected by the Engineer and Contractor for impact damage such as but not limited to gouges, sharp dents, cracks, or other damage prior to any other work related to heat straightening commencing. All areas identified as having impact damage shall have the paint *and coating* removed by abrasive blasting, hand tool cleaning, power tool cleaning, or water blasting. The existing coating shall not be removed by flame or heat. The steel members in the areas identified as having damage resulting from an impact shall be checked for fine cracks using liquid penetrant testing in accordance with ASTM E165 or magnetic particle testing in accordance with ASTM E709.

(a) NDT Testing and Reporting Requirements

The testing shall be performed on surfaces that are clean, dry, and free of contaminants such as oil, grease, rust, weld flux, spatter, paint, *coatings*, and any other contaminant detrimental to NDT testing. A minimum visible light having an intensity of 200 ft-candles and 2,150 lux shall be provided.

SECTION 729, BEGIN LINE 121, INSERT AS FOLLOWS:

729.07 Surface Preparation of Area to be Heated

Before cutting or heating any steel member, *all paint and coating* shall be removed from inside the limits of the heat straightening area. Surface preparation shall be in accordance with 619.08(a) and either 619.08(d) or 619.08(h).

SECTION 729, BEGIN LINE 238, DELETE AND INSERT AS FOLLOWS:

729.15 ~~Painting~~Coating

REVISION TO STANDARD SPECIFICATIONS AND SPECIAL PROVISIONS

- SECTION 101 – DEFINITIONS AND TERMS
- SECTION 104 – SCOPE OF WORK
- SECTION 202 – REMOVAL OF STRUCTURES AND OBSTRUCTIONS
- SECTION 203 – EXCAVATION AND EMBANKMENT
- SECTION 604 – SIDEWALKS, CURB RAMPS, STEPS, AND HANDRAILS
- SECTION 619 – COATING BRIDGE STEEL
- SECTION 711 – STEEL STRUCTURES
- SECTION 712 – TIMBER STRUCTURES
- SECTION 729 – HEAT STRAIGHTENING OF STEEL MEMBERS IN THE FIELD
- SECTION 801 – TRAFFIC CONTROLS FOR CONSTRUCTION AND MAINTENANCE OPERATIONS
- SECTION 802 – SIGNS
- SECTION 805 – TRAFFIC SIGNALS
- SECTION 807 – HIGHWAY ILLUMINATION
- SECTION 909 – COATINGS, PAINTS, AND LIQUID EPOXY
- 619-B-314 ALTERNATE FINISH COAT FOR PARTIAL PAINT SYSTEM (PROPOSED TO DISCONTINUE)
- 620-R-483 SOUND BARRIER SYSTEMS

Upon completion and acceptance of the heat straightened steel members, the Contractor shall clean, prime, and ~~paint~~coat the steel members. Surface preparation shall be in accordance with 729.07. The ~~paint~~coating system shall be in accordance with 619.09(b). ~~Painting~~Coating shall be in accordance with 619.10. All exposed surfaces on heat-straightened steel members shall be fully ~~paint~~edcoated from the edge of the nearest splice plate or steel member end outside the heat straightened area to the nearest splice plate or steel member end on the other side of the heat straightened area. The color of the top coat shall be a similar color to match the color of the existing bridge.

SECTION 801, BEGIN LINE 11, DELETE AND INSERT AS FOLLOWS:

801.02 Materials

Materials shall be in accordance with the following:

Automated Flagger Assistance Devices	923.08
Coarse Aggregate, Class D or Higher, Size No. 73	904.03
Construction Warning Lights	923.03
Delineator Posts	910.15
Delineators	926.02
Field Paint Coatings for Wood or Metal	909.04
Flashing Arrow Sign	923.04

SECTION 802, BEGIN LINE 206, DELETE AND INSERT AS FOLLOWS:

4. Bridge Brackets

The location of the sign bracket may be shifted to avoid joints or stiffeners on the bridge. Before placing aluminum in contact with concrete, both the concrete and aluminum surfaces shall be coated with an aluminum-impregnated caulking compound. Where aluminum surfaces are to be placed in contact with steel, the steel surface shall be given one coat of ~~zinc chromate paint~~ ~~organic zinc primer~~coating and the aluminum surfaces shall be coated with an aluminum-impregnated caulking compound before placement. After the bolts have been tightened, the excess caulking compound shall be removed. All openings around the flanges shall be fully ~~paint~~edcoated and shall be flush with the caulking compound.

SECTION 802, BEGIN LINE 447, DELETE AND INSERT AS FOLLOWS:

REVISION TO STANDARD SPECIFICATIONS AND SPECIAL PROVISIONS

- SECTION 101 – DEFINITIONS AND TERMS
- SECTION 104 – SCOPE OF WORK
- SECTION 202 – REMOVAL OF STRUCTURES AND OBSTRUCTIONS
- SECTION 203 – EXCAVATION AND EMBANKMENT
- SECTION 604 – SIDEWALKS, CURB RAMPS, STEPS, AND HANDRAILS
- SECTION 619 – COATING BRIDGE STEEL
- SECTION 711 – STEEL STRUCTURES
- SECTION 712 – TIMBER STRUCTURES
- SECTION 729 – HEAT STRAIGHTENING OF STEEL MEMBERS IN THE FIELD
- SECTION 801 – TRAFFIC CONTROLS FOR CONSTRUCTION AND MAINTENANCE OPERATIONS
- SECTION 802 – SIGNS
- SECTION 805 – TRAFFIC SIGNALS
- SECTION 807 – HIGHWAY ILLUMINATION
- SECTION 909 – COATINGS, PAINTS, AND LIQUID EPOXY
- 619-B-314 ALTERNATE FINISH COAT FOR PARTIAL PAINT SYSTEM (PROPOSED TO DISCONTINUE)
- 620-R-483 SOUND BARRIER SYSTEMS

The cost of furnishing and applying aluminum-impregnated caulking compound and zinc chromate paintorganic zinc primercoating as required in 802.07, shall be included in the cost of the pay items in this section.

SECTION 805, BEGIN LINE 84, DELETE AND INSERT AS FOLLOWS:

All existing painted metallic signal equipment to be reused, such as pedestals, bases, controller cabinets, signal weatherheads, pipe arms, shall be cleaned and paintedcoated with two coats of highway-yellow enamel in accordance with 909.02(c). Existing metallic signal heads to be reused shall be paintedcoated with two coats of black or highway-yellow enamel as directed by the Engineer and in accordance with 909.02(c). Aluminum poles and signal support structures shall not be painted.

SECTION 805, BEGIN LINE 156, DELETE AND INSERT AS FOLLOWS:

805.04 Pole Installation

Working drawings for strain poles or cantilever structures shall be provided in accordance with 105.02. Metal poles shall be erected on concrete foundations and shall be reasonably plumb after installation of signal heads. The handhole side of the pole shall be at right angles to the direction of the signal cantilever arm or span, catenary, and tether. Signal cables shall be brought up inside the poles. Any steel pole, signal cantilever arm, or hardware not galvanized shall be paintedcoated with the structural steel coating system in accordance with 619.09(a). The surface shall be prepared in accordance with 619.08(a) and 619.08(d). PaintCoatings shall be applied in accordance with 619. All rust, scale, and dirt shall be cleaned from the metal surface so that paintthe coating adheres to the surface.

The construction of concrete foundations shall be in accordance with 805.13. Timber poles shall be set a minimum of 7 ft in the ground and raked 12 in.

SECTION 807, BEGIN LINE 12, DELETE AND INSERT AS FOLLOWS:

807.02 Materials

Materials shall be in accordance with the following:

Casting for Handholes.....	922.17(a)
Coarse Aggregate, Class D or Higher, Size No. 53 ...	904.03
Coatings, Paints, and Liquid Epoxy	909

REVISION TO STANDARD SPECIFICATIONS AND SPECIAL PROVISIONS

- SECTION 101 – DEFINITIONS AND TERMS
- SECTION 104 – SCOPE OF WORK
- SECTION 202 – REMOVAL OF STRUCTURES AND OBSTRUCTIONS
- SECTION 203 – EXCAVATION AND EMBANKMENT
- SECTION 604 – SIDEWALKS, CURB RAMPS, STEPS, AND HANDRAILS
- SECTION 619 – COATING BRIDGE STEEL
- SECTION 711 – STEEL STRUCTURES
- SECTION 712 – TIMBER STRUCTURES
- SECTION 729 – HEAT STRAIGHTENING OF STEEL MEMBERS IN THE FIELD
- SECTION 801 – TRAFFIC CONTROLS FOR CONSTRUCTION AND MAINTENANCE OPERATIONS
- SECTION 802 – SIGNS
- SECTION 805 – TRAFFIC SIGNALS
- SECTION 807 – HIGHWAY ILLUMINATION
- SECTION 909 – COATINGS, PAINTS, AND LIQUID EPOXY
- 619-B-314 ALTERNATE FINISH COAT FOR PARTIAL PAINT SYSTEM (PROPOSED TO DISCONTINUE)
- 620-R-483 SOUND BARRIER SYSTEMS

Concrete, Class A.....	702
Conduit.....	922.19
Highway Illumination Materials	920.01
Line Hardware	922.10(e)1
Paint	909
Reinforced Concrete Pipe	907.02
Reinforcing Bars	910.01

SECTION 807, BEGIN LINE 156546, DELETE AND INSERT AS FOLLOWS:

2. Sign Luminaires

Connections in which plain and galvanized steel are in contact shall be protected such that aluminum surfaces shall receive one coat of zinc chromate primer. Steel surfaces shall be prepared in accordance with 619.08(a), and 619.08(d), and ~~paint~~~~coated~~ with the structural steel ~~paint~~~~coating~~ system in accordance with 619.09(a). All ~~paint~~~~coatings~~ shall be allowed to cure before assembly. Conduit fittings, if required, shall be watertight. Required conduit shall be either rigid or flexible as necessary. Conduit shall not be clamped to a sign panel.

SECTION 909, BEGIN LINE 1, DELETE AND INSERT AS FOLLOWS:

SECTION 909 – COATINGS, PAINTS, AND LIQUID EPOXY

909.01 General Requirements

All necessary facilities for inspection of materials and manufacture of coatings, paints, and ingredients shall be granted. Free access to all parts of the premises where any or all of these products are being prepared shall be allowed. SDSs shall be provided.

~~Paints and eCoatings and paints~~ shall be furnished ready for use without modification and shall not settle, cake, curdle, liver, gel, or develop excessive change in viscosity between time of manufacture and time of use. It shall remain capable of being readily dispersed with a paddle, or other approved methods, to a consistency appropriate for the intended use. ~~Paints and eCoatings and paints~~ may be sampled and tested at any time prior to use. ~~Paints and coatings that are part of a steel coating system listed on the QPL of Structural Steel Coating Systems shall be submitted in an unopened, full, and complete kit for testing.~~

REVISION TO STANDARD SPECIFICATIONS AND SPECIAL PROVISIONS

SECTION 101 – DEFINITIONS AND TERMS
 SECTION 104 – SCOPE OF WORK
 SECTION 202 – REMOVAL OF STRUCTURES AND OBSTRUCTIONS
 SECTION 203 – EXCAVATION AND EMBANKMENT
 SECTION 604 – SIDEWALKS, CURB RAMPS, STEPS, AND HANDRAILS
 SECTION 619 – COATING BRIDGE STEEL
 SECTION 711 – STEEL STRUCTURES
 SECTION 712 – TIMBER STRUCTURES
 SECTION 729 – HEAT STRAIGHTENING OF STEEL MEMBERS IN THE FIELD
 SECTION 801 – TRAFFIC CONTROLS FOR CONSTRUCTION AND MAINTENANCE OPERATIONS
 SECTION 802 – SIGNS
 SECTION 805 – TRAFFIC SIGNALS
 SECTION 807 – HIGHWAY ILLUMINATION
 SECTION 909 – COATINGS, PAINTS, AND LIQUID EPOXY
 619-B-314 ALTERNATE FINISH COAT FOR PARTIAL PAINT SYSTEM (PROPOSED TO DISCONTINUE)
 620-R-483 SOUND BARRIER SYSTEMS

~~Individual~~ *Coatings that are part of a coating system listed on the QPL of Structural Steel Coating Systems and individual* batches of organic zinc primer and waterborne finish ~~paint~~ *coatings* listed on the QPL of Coating Formulations shall be submitted in ~~an~~ unopened, full, and complete kits for testing.

If, for any reason, re-sampling and re-testing following initial or prior acceptance is indicated, the latest test results shall prevail over all previous tests for material that has not been used. Previously accepted ~~paint or~~ *coatings or paints* that are stored for future use may be re-sampled and re-tested.

~~Paints and~~ *Coatings and paints* shall be delivered in new containers of such strength, durability, design, fabrication, and material that the ~~paint~~ *material* shall be suitably protected in transit and in storage against any change in characteristics which would cause rejection based on laboratory or field evaluation. Each container shall bear a label which shows the name and address of the manufacturer, kind of ~~paint or~~ *coating or paint*, formula identification, date of manufacture, and lot or batch number. The container shall be filled so the net weight of the material in the container equals the product of the weight per gallon at 77°F and the stated number of gallons in the container.

All containers shall be labeled in accordance with the OSHA requirements for labeling of hazardous chemicals as described in the Hazardous Communications Standard.

All coatings and paints shall comply with current IDEM VOC regulations, and the cured film of the coatings and paints shall not contain toxic heavy metals above IDEM regulatory levels that would require classification as a hazardous waste.

909.02 Coatings For Metal

~~Paints~~ *Coatings* for metal surfaces shall be in accordance with the requirements shown below.

SECTION 909, BEGIN LINE 61, DELETE AND INSERT AS FOLLOWS:

2. Organic Zinc Primer

Organic zinc primer shall be a self-curing primer. It shall be in accordance with

REVISION TO STANDARD SPECIFICATIONS AND SPECIAL PROVISIONS

- SECTION 101 – DEFINITIONS AND TERMS
- SECTION 104 – SCOPE OF WORK
- SECTION 202 – REMOVAL OF STRUCTURES AND OBSTRUCTIONS
- SECTION 203 – EXCAVATION AND EMBANKMENT
- SECTION 604 – SIDEWALKS, CURB RAMPS, STEPS, AND HANDRAILS
- SECTION 619 – COATING BRIDGE STEEL
- SECTION 711 – STEEL STRUCTURES
- SECTION 712 – TIMBER STRUCTURES
- SECTION 729 – HEAT STRAIGHTENING OF STEEL MEMBERS IN THE FIELD
- SECTION 801 – TRAFFIC CONTROLS FOR CONSTRUCTION AND MAINTENANCE OPERATIONS
- SECTION 802 – SIGNS
- SECTION 805 – TRAFFIC SIGNALS
- SECTION 807 – HIGHWAY ILLUMINATION
- SECTION 909 – COATINGS, PAINTS, AND LIQUID EPOXY
- 619-B-314 ALTERNATE FINISH COAT FOR PARTIAL PAINT SYSTEM (PROPOSED TO DISCONTINUE)
- 620-R-483 SOUND BARRIER SYSTEMS

SSPC Paint Specification No. 20, Type II. The organic zinc primer shall be compatible with inorganic zinc and finish coats *or* paints already on the bridge. The color shall be able to produce a distinct contrast with blast cleaned metal surface and the finish coat. The cured organic zinc film shall be compatible with a ~~top coating of~~ waterborne finish coat ~~paint~~.

The organic zinc primer shall also be in accordance with the following requirements:

Viscosity, ASTM D562, Krebs Units	70 – 100
Viscosity variation from the initially approved formulation, ASTM D562, Krebs Units, max.	±10
Volatile organic compounds, ASTM D3960, max.	419 g/L
Weight/volume, ASTM D1475, 25°C, min.	2.040 kg/L
Weight/volume variation from the initially approved formulation, max.	±0.048 kg/L
Dry time, ASTM D1640, 6 mils wet film thickness on a tin coated steel panel, max.:	
Set to touch	1 h
Dry hard	24 h

SECTION 909, BEGIN LINE 107, DELETE AND INSERT AS FOLLOWS:

The infrared spectrum of the vehicle *component* when extracted from the organic zinc primer, in accordance with ASTM D3168, shall match the infrared spectrum of the vehicle *component* of the sample submitted for formulation approval.

The cured film shall not contain any toxic heavy metals above the limits of the regulatory levels of 40 CFR 261.24, Table 1. The cured ~~paintcoating~~ shall not contain any other material which will require characterization as a hazardous waste for the disposal of the dried film.

3. Furnishing and Use

Only zinc primers from the QPL of Coating Formulations shall be used. Zinc primers will be placed and maintained on the QPL of Coating Formulations in accordance with ITM 606.

REVISION TO STANDARD SPECIFICATIONS AND SPECIAL PROVISIONS

- SECTION 101 – DEFINITIONS AND TERMS
- SECTION 104 – SCOPE OF WORK
- SECTION 202 – REMOVAL OF STRUCTURES AND OBSTRUCTIONS
- SECTION 203 – EXCAVATION AND EMBANKMENT
- SECTION 604 – SIDEWALKS, CURB RAMPS, STEPS, AND HANDRAILS
- SECTION 619 – COATING BRIDGE STEEL
- SECTION 711 – STEEL STRUCTURES
- SECTION 712 – TIMBER STRUCTURES
- SECTION 729 – HEAT STRAIGHTENING OF STEEL MEMBERS IN THE FIELD
- SECTION 801 – TRAFFIC CONTROLS FOR CONSTRUCTION AND MAINTENANCE OPERATIONS
- SECTION 802 – SIGNS
- SECTION 805 – TRAFFIC SIGNALS
- SECTION 807 – HIGHWAY ILLUMINATION
- SECTION 909 – COATINGS, PAINTS, AND LIQUID EPOXY
- 619-B-314 ALTERNATE FINISH COAT FOR PARTIAL PAINT SYSTEM (PROPOSED TO DISCONTINUE)
- 620-R-483 SOUND BARRIER SYSTEMS

(b) Epoxy Intermediate Paint Coat

Epoxy intermediate ~~paint coating~~ shall be a two-component ~~coating~~ consisting of an epoxy resin and a curing agent, together with prime and filler pigments, colorants, gellant, leveling agents, and solvents. When mixed, this coating shall be suitable for application over inorganic and organic zinc primers and shall be compatible with a polyurethane finish coat. The color of this coating shall contrast significantly from the other coatings within the coating system.

The mixed ~~paint coating~~ shall be in accordance with the following requirements:

Volatile organic compounds, ASTM D3960, max.	336 g/L
Volume solids, ASTM D2697, min.	60%
Set to touch, ASTM D1640, 6 mils wet film thickness, max.	4 h
Weight/volume variation from the initially approved formulation, ASTM D1475, 25°C, max.	0.060 kg/L
Total solids variation from the initially approved formulation, ASTM D2369, max.	3.0%

The coating shall be applied within the pot life recommended by the ~~paint coating~~ manufacturer with no evidence of gelation. The coating shall be in a free-flowing condition and easily sprayed.

The infrared spectrum of each component and of the mixed coating shall match the spectrums of the initially approved batch.

(c) Polyurethane Finish Coat

Polyurethane finish coat shall be a two-component polyester or acrylic aliphatic polyurethane suitable for use as a finish coat over ~~an~~ epoxy intermediate ~~paint coating~~.

The mixed ~~paint coating~~ shall be in accordance with the following requirements:

Volatile organic compounds, ASTM D3960, max.	336 g/L
Volume solids, ASTM D2697, min.	60%
Set to touch, ASTM D1640, 5 mils wet film thickness, min.	30 minutes

REVISION TO STANDARD SPECIFICATIONS AND SPECIAL PROVISIONS

- SECTION 101 – DEFINITIONS AND TERMS
- SECTION 104 – SCOPE OF WORK
- SECTION 202 – REMOVAL OF STRUCTURES AND OBSTRUCTIONS
- SECTION 203 – EXCAVATION AND EMBANKMENT
- SECTION 604 – SIDEWALKS, CURB RAMPS, STEPS, AND HANDRAILS
- SECTION 619 – COATING BRIDGE STEEL
- SECTION 711 – STEEL STRUCTURES
- SECTION 712 – TIMBER STRUCTURES
- SECTION 729 – HEAT STRAIGHTENING OF STEEL MEMBERS IN THE FIELD
- SECTION 801 – TRAFFIC CONTROLS FOR CONSTRUCTION AND MAINTENANCE OPERATIONS
- SECTION 802 – SIGNS
- SECTION 805 – TRAFFIC SIGNALS
- SECTION 807 – HIGHWAY ILLUMINATION
- SECTION 909 – COATINGS, PAINTS, AND LIQUID EPOXY
- 619-B-314 ALTERNATE FINISH COAT FOR PARTIAL PAINT SYSTEM (PROPOSED TO DISCONTINUE)
- 620-R-483 SOUND BARRIER SYSTEMS

Total solids ASTM D2369, min.	70%
Specular gloss, 60°, 10 ±0.5 mils wet film thickness on a tin coated steel panel, dried 48 h, ASTM D523, min.	75
Viscosity, ASTM D562, Krebs Units, max.	10030
Contrast ratio, ASTM D2805, 5 ±0.5 mils wet film thickness, dried 24 h on opacity chart 2A or 2C, min.	0.957
Dry hard, ASTM D1640, 5 mils wet film thickness, max.	24 h

The infrared spectrum of each component and of the mixed coating shall match the spectrum of the initially approved batch.

The color of the dried ~~paint~~ film shall match the color number of SAE-AMS-STD-595 as follows:

Color No.	Color
13538	Yellow
13711	Buff
14260	Green
15450	Light Blue
17038	Black
17886	White

(d) Waterborne Finish ~~Paint~~Coat

The waterborne finish coating shall be a single package, high build acrylic emulsion for use as a finish coat over inorganic and organic zinc primers. It shall be compatible with and adhere to the cured zinc primers.

SECTION 909, BEGIN LINE 185, DELETE AND INSERT AS FOLLOWS:

3. Mixed ~~Paint~~Coating Properties

The mixed ~~paint~~coating shall be in accordance with the following requirements:

Viscosity, ASTM D562, Krebs Units	80 – 110
Weight/volume, ASTM D1475, variation from the initially approved formulation, 25°C, max.	0.024 kg/L

REVISION TO STANDARD SPECIFICATIONS AND SPECIAL PROVISIONS

- SECTION 101 – DEFINITIONS AND TERMS
- SECTION 104 – SCOPE OF WORK
- SECTION 202 – REMOVAL OF STRUCTURES AND OBSTRUCTIONS
- SECTION 203 – EXCAVATION AND EMBANKMENT
- SECTION 604 – SIDEWALKS, CURB RAMPS, STEPS, AND HANDRAILS
- SECTION 619 – COATING BRIDGE STEEL
- SECTION 711 – STEEL STRUCTURES
- SECTION 712 – TIMBER STRUCTURES
- SECTION 729 – HEAT STRAIGHTENING OF STEEL MEMBERS IN THE FIELD
- SECTION 801 – TRAFFIC CONTROLS FOR CONSTRUCTION AND MAINTENANCE OPERATIONS
- SECTION 802 – SIGNS
- SECTION 805 – TRAFFIC SIGNALS
- SECTION 807 – HIGHWAY ILLUMINATION
- SECTION 909 – COATINGS, PAINTS, AND LIQUID EPOXY
- 619-B-314 ALTERNATE FINISH COAT FOR PARTIAL PAINT SYSTEM (PROPOSED TO DISCONTINUE)
- 620-R-483 SOUND BARRIER SYSTEMS

Pigment grind, ASTM D1210, Hegman, min.	5
Total solids, % by weight, ASTM D2369, min.	48
Dry time, ASTM D1640, 3 mils wet film thickness on a tin coated steel panel, max.:	
Set to touch	1 h
Dry hard	24 h
Contrast ratio, ASTM D2805, 5 ±0.5 mils wet film thickness dried 24 h on opacity chart 2A or 2C, min.	0.97
Specular gloss, 60°, 10 ±0.5 mils wet film thickness on a tin coated steel panel, dried 48 h, ASTM D523, max.	30
pH, ASTM E70	7.0 – 9.5
Volatile organic compounds, ASTM D3960, max.	180 g/L

The infrared spectrum of the vehicle *component* when extracted from the mixed *paintcoating* in accordance with ASTM D3168 shall match the infrared spectrum of the *vehicle component of the* sample submitted for formulation approval.

The mixed *paintcoating* shall be in accordance with the requirements of Sections 5.4 through 5.17 of SSPC Paint Specification No. 24.

The cured waterborne finish *paintcoat* shall not contain any toxic heavy metals above the limits of the regulatory levels of 40 CFR 261.24, Table 1. The cured *paintcoating* shall not contain any other material which will require characterization as a hazardous waste for the disposal of the dried film.

4. Color

The color of the dried *paint* film shall match the color number of SAE-AMS-STD-595 as follows:

Color No.	Color
23538	Yellow
23717	Buff
24227	Green
24466	Light Green

REVISION TO STANDARD SPECIFICATIONS AND SPECIAL PROVISIONS

- SECTION 101 – DEFINITIONS AND TERMS
- SECTION 104 – SCOPE OF WORK
- SECTION 202 – REMOVAL OF STRUCTURES AND OBSTRUCTIONS
- SECTION 203 – EXCAVATION AND EMBANKMENT
- SECTION 604 – SIDEWALKS, CURB RAMPS, STEPS, AND HANDRAILS
- SECTION 619 – COATING BRIDGE STEEL
- SECTION 711 – STEEL STRUCTURES
- SECTION 712 – TIMBER STRUCTURES
- SECTION 729 – HEAT STRAIGHTENING OF STEEL MEMBERS IN THE FIELD
- SECTION 801 – TRAFFIC CONTROLS FOR CONSTRUCTION AND MAINTENANCE OPERATIONS
- SECTION 802 – SIGNS
- SECTION 805 – TRAFFIC SIGNALS
- SECTION 807 – HIGHWAY ILLUMINATION
- SECTION 909 – COATINGS, PAINTS, AND LIQUID EPOXY
- 619-B-314 ALTERNATE FINISH COAT FOR PARTIAL PAINT SYSTEM (PROPOSED TO DISCONTINUE)
- 620-R-483 SOUND BARRIER SYSTEMS

25526	Light Blue
27038	Black
27780	White

5. Furnishing and Use

Only waterborne finish **paintcoatings** from the QPL of Coating Formulations shall be used. Waterborne finish **paintcoating** formulations will be placed and maintained on the QPL of Coating Formulations in accordance with ITM 606.

(e) Finish Coat for Weathering Steel

The finish coat shall be an aliphatic polyurethane or a waterborne acrylic **paintcoating**, and the **color of the** dried **paint** film shall match color No. 20045 of SAE-AMS-STD-595. It shall be suitable for use as a finish coat over **an** epoxy intermediate **paintcoating**. The mixed **paintcoating** shall be in accordance with the following requirements.

For **an** aliphatic polyurethane **paintcoating**:

- Weight/volume, ASTM D1475, 25°C, min.1.200 kg/L
- Total solids, % by weight, ASTM D2369, min.60
- ~~Volatile Organic Compounds, ASTM D3960, max.336 g/L~~
- Specular gloss, 60°, 10 ±0.5 mils wet film thickness
 on a tin coated steel panel, dried 48 h, ASTM D523, max.30

For **a** waterborne acrylic **paintcoating**:

- Weight/volume, ASTM D1475, 25°C, min.1.200 kg/L
- Total solids, % by weight, ASTM D2369, min.48
- ~~Volatile Organic Compounds, ASTM D3960, max.180 g/L~~
- Specular gloss, 60°, 10 ±0.5 mils wet film thickness
 on a tin coated steel panel, dried 48 h, ASTM D523, max.30

909.03 Structural Steel Coating System

This coating system shall consist of an inorganic zinc primer, an epoxy intermediate

REVISION TO STANDARD SPECIFICATIONS AND SPECIAL PROVISIONS

SECTION 101 – DEFINITIONS AND TERMS
 SECTION 104 – SCOPE OF WORK
 SECTION 202 – REMOVAL OF STRUCTURES AND OBSTRUCTIONS
 SECTION 203 – EXCAVATION AND EMBANKMENT
 SECTION 604 – SIDEWALKS, CURB RAMPS, STEPS, AND HANDRAILS
 SECTION 619 – COATING BRIDGE STEEL
 SECTION 711 – STEEL STRUCTURES
 SECTION 712 – TIMBER STRUCTURES
 SECTION 729 – HEAT STRAIGHTENING OF STEEL MEMBERS IN THE FIELD
 SECTION 801 – TRAFFIC CONTROLS FOR CONSTRUCTION AND MAINTENANCE OPERATIONS
 SECTION 802 – SIGNS
 SECTION 805 – TRAFFIC SIGNALS
 SECTION 807 – HIGHWAY ILLUMINATION
 SECTION 909 – COATINGS, PAINTS, AND LIQUID EPOXY
 619-B-314 ALTERNATE FINISH COAT FOR PARTIAL PAINT SYSTEM (PROPOSED TO DISCONTINUE)
 620-R-483 SOUND BARRIER SYSTEMS

~~paintcoat~~, and a polyurethane finish coat for the ~~painting~~ coating of steel bridges and other structural steel. All coatings within any coating system shall be manufactured by the same manufacturer and shall be compatible with one another. All coatings shall be in accordance with 909.02.

SECTION 909, BEGIN LINE 277, DELETE AND INSERT AS FOLLOWS:

909.04 Field ~~Paint~~Coatings for Wood or Metal

The primers for field ~~paint~~coatings shall be formulated for minimal surface preparation, provide adhesion to the substrate and be compatible with the finish coat. The primers shall not contain lead, chromium, or other heavy metals which would require classification as a hazardous waste upon removal. The primers shall comply with the current IDEM VOC regulations and shall be used as follows:

- a. For unpainted galvanized steel and other ferrous metals, use one coat of a zinc dust-zinc oxide pigmented primer.
- b. For non-ferrous metals, use one coat of primer formulated for use on non-ferrous metals.

The ~~field paint~~ finish coat shall be an exterior type coating. It shall be chalk resistant, gloss retentive, and suitable for application by brush, roller, or spray. This coating shall comply with the current IDEM VOC regulations and shall not contain lead, chromium, or other heavy metals which would require classification as a hazardous waste upon removal. The color of this coating shall be as specified.

REVISION TO STANDARD SPECIFICATIONS AND SPECIAL PROVISIONS

SECTION 101 – DEFINITIONS AND TERMS
SECTION 104 – SCOPE OF WORK
SECTION 202 – REMOVAL OF STRUCTURES AND OBSTRUCTIONS
SECTION 203 – EXCAVATION AND EMBANKMENT
SECTION 604 – SIDEWALKS, CURB RAMPS, STEPS, AND HANDRAILS
SECTION 619 – COATING BRIDGE STEEL
SECTION 711 – STEEL STRUCTURES
SECTION 712 – TIMBER STRUCTURES
SECTION 729 – HEAT STRAIGHTENING OF STEEL MEMBERS IN THE FIELD
SECTION 801 – TRAFFIC CONTROLS FOR CONSTRUCTION AND MAINTENANCE OPERATIONS
SECTION 802 – SIGNS
SECTION 805 – TRAFFIC SIGNALS
SECTION 807 – HIGHWAY ILLUMINATION
SECTION 909 – COATINGS, PAINTS, AND LIQUID EPOXY
619-B-314 ALTERNATE FINISH COAT FOR PARTIAL PAINT SYSTEM (PROPOSED TO DISCONTINUE)
620-R-483 SOUND BARRIER SYSTEMS

~~619-B-314 ALTERNATE FINISH COAT FOR PARTIAL PAINT SYSTEM~~

~~(Revised 05-20-23)~~

The Standard Specifications are revised as follows:

SECTION 619, BEGIN LINE 436, DELETE AND INSERT AS FOLLOWS:

619.09 Paint Systems

Paint systems shall be applied in accordance with the manufacturer's recommendations. The dry film thickness of a paint coating will be measured with a calibrated film thickness gauge in accordance with SSPC PA 2. All paint coatings shall have a dry film thickness not less than 80% of the required dry film thickness.

(a) Structural Steel Paint System

The coating system shall consist of an inorganic zinc primer with a dry film thickness of 3 mil, an epoxy intermediate coat with a dry film thickness of 4 mil, and a polyurethane finish coat with a dry film thickness of 3 mil for the painting of steel bridges and other structural steel.

(b) Partial Paint System

The coating system shall consist of ~~organic zinc primer with a dry film thickness of 3 mil and a waterborne finish coat with a dry film thickness of 3 mil~~ *one of the following for partial painting of steel bridges and other structural steel. The primer and finish coat may be from different manufacturers. The Contractor shall ensure that the primer and selected finish coat are compatible.*

1. Organic zinc primer with a dry film thickness of 3 mil and a waterborne finish coat with a dry film thickness of 3 mil.

2. Organic zinc primer with a dry film thickness of 3 mil and a polysiloxane finish coat with a dry film thickness as noted below. The polysiloxane finish coat shall be one of those listed below.

a. Carboxane 2000, 4 mil,

b. Interfine 2700, 4 mil,

REVISION TO STANDARD SPECIFICATIONS AND SPECIAL PROVISIONS

- SECTION 101 – DEFINITIONS AND TERMS
- SECTION 104 – SCOPE OF WORK
- SECTION 202 – REMOVAL OF STRUCTURES AND OBSTRUCTIONS
- SECTION 203 – EXCAVATION AND EMBANKMENT
- SECTION 604 – SIDEWALKS, CURB RAMPS, STEPS, AND HANDRAILS
- SECTION 619 – COATING BRIDGE STEEL
- SECTION 711 – STEEL STRUCTURES
- SECTION 712 – TIMBER STRUCTURES
- SECTION 729 – HEAT STRAIGHTENING OF STEEL MEMBERS IN THE FIELD
- SECTION 801 – TRAFFIC CONTROLS FOR CONSTRUCTION AND MAINTENANCE OPERATIONS
- SECTION 802 – SIGNS
- SECTION 805 – TRAFFIC SIGNALS
- SECTION 807 – HIGHWAY ILLUMINATION
- SECTION 909 – COATINGS, PAINTS, AND LIQUID EPOXY
- 619-B-314 ALTERNATE FINISH COAT FOR PARTIAL PAINT SYSTEM (PROPOSED TO DISCONTINUE)
- 620-R-483 SOUND BARRIER SYSTEMS

- c. *Polysiloxane 1K, 2.5 mil,*
- d. *PSX 700, 4 mil, or*
- e. *Sher-Loxane, 4 mil.*

3. *Organic zinc primer with a dry film thickness of 3 mil and a polyurethane finish coat with a dry film thickness of 3 mil. The polyurethane finish coat shall be one of those listed below.*

- a. *Amercoat 450 HS,*
- b. *Carbothane 134 HS,*
- c. *INDOT Acrylic Urethane or*
- d. *Interthane 990 HS.*

Polyurethane finish coat used as a finish coat in the partial paint system shall be in accordance with 909.02(c) with the exception that the specular gloss shall be a minimum of 30 and the color of the dried paint film shall be in accordance with either 909.02(c), or the following:

<i>Color Number</i>	<i>Color</i>
<i>23538</i>	<i>Yellow</i>
<i>23711</i>	<i>Buff</i>
<i>24260</i>	<i>Green</i>
<i>24466</i>	<i>Light Green</i>
<i>25488</i>	<i>Light Blue</i>
<i>27038</i>	<i>Black</i>
<i>27886</i>	<i>White</i>

SECTION 909, BEGIN LINE 61, INSERT AS FOLLOWS:

2. Organic Zinc Primer

Organic zinc primer shall be a self-curing primer. It shall be in accordance with SSPC Paint Specification No. 20, Type II. The organic zinc primer shall be compatible with inorganic zinc and finish coat paints already on the bridge. The color shall be able to produce a distinct contrast with blast cleaned metal surface and the finish coat. The cured

REVISION TO STANDARD SPECIFICATIONS AND SPECIAL PROVISIONS

- SECTION 101 – DEFINITIONS AND TERMS
- SECTION 104 – SCOPE OF WORK
- SECTION 202 – REMOVAL OF STRUCTURES AND OBSTRUCTIONS
- SECTION 203 – EXCAVATION AND EMBANKMENT
- SECTION 604 – SIDEWALKS, CURB RAMPS, STEPS, AND HANDRAILS
- SECTION 619 – COATING BRIDGE STEEL
- SECTION 711 – STEEL STRUCTURES
- SECTION 712 – TIMBER STRUCTURES
- SECTION 729 – HEAT STRAIGHTENING OF STEEL MEMBERS IN THE FIELD
- SECTION 801 – TRAFFIC CONTROLS FOR CONSTRUCTION AND MAINTENANCE OPERATIONS
- SECTION 802 – SIGNS
- SECTION 805 – TRAFFIC SIGNALS
- SECTION 807 – HIGHWAY ILLUMINATION
- SECTION 909 – COATINGS, PAINTS, AND LIQUID EPOXY
- 619-B-314 ALTERNATE FINISH COAT FOR PARTIAL PAINT SYSTEM (PROPOSED TO DISCONTINUE)
- 620-R-483 SOUND BARRIER SYSTEMS

organic zinc film shall be compatible with a top coating of *either* waterborne, *polysiloxane*, or *polyurethane* finish coat paint.

The organic zinc primer shall also be in accordance with the following requirements.

SECTION 909, BEGIN LINE 143, INSERT AS FOLLOWS:

(c) Polyurethane Finish Coat

Polyurethane finish coat shall be a two-component polyester or acrylic aliphatic polyurethane suitable for use as a finish coat over *either* epoxy intermediate paint for the structural steel coating system or over organic zinc primer for partial painting of steel bridges.

SECTION 909, AFTER LINE 247, INSERT AS FOLLOWS:

(f) Polysiloxane Finish Coat

Polysiloxane finish coat shall be suitable for use as a finish coat over organic zinc primer for partial painting of steel bridges.

The mixed paint shall be in accordance with the following requirements.

Volatile organic compounds, ASTM D3960, max.	336 g/L
Volume solids, ASTM D2697, min.	55%
Total solids ASTM D2369, min.	65%
Specular gloss, 60°, ASTM D523, min.....	30
Contrast ratio, ASTM D2805, 5 ±0.5 mils wet film thickness, dried 24 h on opacity chart 2A or 2C, min.	0.95

The color of the dried paint film shall match the color number of SAE-AMS-STD-595 as follows:

Color Number	Color
23538	Yellow
23717	Buff
24227	Green

REVISION TO STANDARD SPECIFICATIONS AND SPECIAL PROVISIONS

- SECTION 101 – DEFINITIONS AND TERMS
- SECTION 104 – SCOPE OF WORK
- SECTION 202 – REMOVAL OF STRUCTURES AND OBSTRUCTIONS
- SECTION 203 – EXCAVATION AND EMBANKMENT
- SECTION 604 – SIDEWALKS, CURB RAMPS, STEPS, AND HANDRAILS
- SECTION 619 – COATING BRIDGE STEEL
- SECTION 711 – STEEL STRUCTURES
- SECTION 712 – TIMBER STRUCTURES
- SECTION 729 – HEAT STRAIGHTENING OF STEEL MEMBERS IN THE FIELD
- SECTION 801 – TRAFFIC CONTROLS FOR CONSTRUCTION AND MAINTENANCE OPERATIONS
- SECTION 802 – SIGNS
- SECTION 805 – TRAFFIC SIGNALS
- SECTION 807 – HIGHWAY ILLUMINATION
- SECTION 909 – COATINGS, PAINTS, AND LIQUID EPOXY
- 619-B-314 ALTERNATE FINISH COAT FOR PARTIAL PAINT SYSTEM (PROPOSED TO DISCONTINUE)
- 620-R-483 SOUND BARRIER SYSTEMS

<i>24466</i>	<i>Light Green</i>
<i>25526</i>	<i>Light Blue</i>
<i>27038</i>	<i>Black</i>
<i>27780</i>	<i>White</i>

FINAL DRAFT MINUTES

REVISION TO STANDARD SPECIFICATIONS AND SPECIAL PROVISIONS

SECTION 101 – DEFINITIONS AND TERMS
SECTION 104 – SCOPE OF WORK
SECTION 202 – REMOVAL OF STRUCTURES AND OBSTRUCTIONS
SECTION 203 – EXCAVATION AND EMBANKMENT
SECTION 604 – SIDEWALKS, CURB RAMPS, STEPS, AND HANDRAILS
SECTION 619 – COATING BRIDGE STEEL
SECTION 711 – STEEL STRUCTURES
SECTION 712 – TIMBER STRUCTURES
SECTION 729 – HEAT STRAIGHTENING OF STEEL MEMBERS IN THE FIELD
SECTION 801 – TRAFFIC CONTROLS FOR CONSTRUCTION AND MAINTENANCE OPERATIONS
SECTION 802 – SIGNS
SECTION 805 – TRAFFIC SIGNALS
SECTION 807 – HIGHWAY ILLUMINATION
SECTION 909 – COATINGS, PAINTS, AND LIQUID EPOXY
619-B-314 ALTERNATE FINISH COAT FOR PARTIAL PAINT SYSTEM (PROPOSED TO DISCONTINUE)
620-R-483 SOUND BARRIER SYSTEMS

620-R-483 SOUND BARRIER SYSTEMS

(Revised 09-15-22)

The Standard Specifications are revised as follows:

SECTION 620, BEGIN LINE 1, DELETE AND INSERT AS FOLLOWS:

SECTION 620 – ~~BLANK SOUND BARRIER SYSTEMS~~

620.01 Description

This work shall consist of furnishing materials and placement of a sound barrier system and a coping in accordance with 105.03.

620.02 General Design Requirements

The sound barrier system shall be either wall mounted, bridge mounted or ground mounted, and shall consist of wall attachments or post foundations, vertical support posts, and sound barrier panels. For the purposes of this section, “panel” is defined as the reflective or absorptive component mounted between the posts, piers or columns.

All appurtenances behind, in front of, under, over, mounted upon, or passing through the wall, including drainage structures, fire hydrant access openings, highway signage, emergency access openings, utilities or other appurtenances shown on the plans, shall be accounted for in the design of the sound barrier system.

If the sound barrier manufacturer needs additional information to complete the design, the Contractor shall be responsible for obtaining such information. The Contractor shall be responsible for field verifying wall locations in areas of all existing traffic poles, utility poles, roadway lighting poles, drainage pipes, underdrain outlets, and bridge expansion joints and all other locations where the sound barrier system may conflict with existing conditions. The wall shall be realigned and designed to box out openings where conflicts occur with existing light poles and traffic control devices. The Contractor shall establish and account for the existing locations of all underdrain outlets, drainage pipes, and bridge expansion joints in the final wall plans. If the Contractor discovers that overhead utilities will be within 6 ft of the sound barrier, the Contractor shall notify the

REVISION TO STANDARD SPECIFICATIONS AND SPECIAL PROVISIONS

SECTION 101 – DEFINITIONS AND TERMS
 SECTION 104 – SCOPE OF WORK
 SECTION 202 – REMOVAL OF STRUCTURES AND OBSTRUCTIONS
 SECTION 203 – EXCAVATION AND EMBANKMENT
 SECTION 604 – SIDEWALKS, CURB RAMPS, STEPS, AND HANDRAILS
 SECTION 619 – COATING BRIDGE STEEL
 SECTION 711 – STEEL STRUCTURES
 SECTION 712 – TIMBER STRUCTURES
 SECTION 729 – HEAT STRAIGHTENING OF STEEL MEMBERS IN THE FIELD
 SECTION 801 – TRAFFIC CONTROLS FOR CONSTRUCTION AND MAINTENANCE OPERATIONS
 SECTION 802 – SIGNS
 SECTION 805 – TRAFFIC SIGNALS
 SECTION 807 – HIGHWAY ILLUMINATION
 SECTION 909 – COATINGS, PAINTS, AND LIQUID EPOXY
 619-B-314 ALTERNATE FINISH COAT FOR PARTIAL PAINT SYSTEM (PROPOSED TO DISCONTINUE)
 620-R-483 SOUND BARRIER SYSTEMS

Engineer in accordance with 104.02 and 105.16.

The sound barrier wall design shall follow the general dimensions of the wall envelope as shown on the plans. The top of the sound barrier shall be at or above the acoustical profile line shown, unless noted. Changes in elevation shall be accomplished by stepping the sound barrier sections at the vertical support posts. Steps shall not exceed 3 ft vertically unless otherwise specified in the plans. Barrier heights shall be selected in groups of no fewer than three successive panels, except where barriers are to be stepped down for barrier termination. The ends of the sound barrier shall be tapered or stepped down to a height of 8 ft within the sound barrier end transitions or as shown on the plans. The bottom of ground mounted sound barrier shall be embedded a minimum of 6 in. into the ground. The bottom of wall mounted or bridge mounted sound barrier shall follow within 3 in. a profile 6 in. below the top of the existing concrete barrier railing or wall.

Caisson footings, vertical support posts, and connections for ground mounted sound barrier shall be designed as specified by the manufacturer, with minimum post spacing of 15 ft. Exceptions will be allowed due to site-specific conditions such as access doors, drainage requirements or utility accommodations. These shall be reviewed and approved through the working drawing process. The foundation design shall use the COM 624P or LPILE Program. The foundation design shall be based on the soil model shown on the plans based on cyclic loading and shall consider the effects of a sloping ground surface. The post deflection shall be limited to L/100, measured from the top of the caisson to the top of the wall. The foundation depth shall not be less than 7.5 ft and shall not exceed the depth of the soil model except where the Contractor elects to drill deeper borings to extend the model. The foundation diameter shall not be less than 18 in. and shall not be less than 6 in. larger than the diagonal dimension of the post being used. The foundation shall be designed by the sound barrier manufacturer. Vertical support posts shall be attached to caisson footings by means of anchor bolts, or embedded wide flange steel posts.

A sound barrier system shall be selected for the type specified from those which are on the QPL of Sound Barrier Systems. The materials used in the fabrication of the sound barrier system shall be the same as those used for qualification of the sound barrier system. Sound Barrier Systems may be considered for addition to the QPL by completing the requirements of ITM 806, Procedure N.

REVISION TO STANDARD SPECIFICATIONS AND SPECIAL PROVISIONS

SECTION 101 – DEFINITIONS AND TERMS
SECTION 104 – SCOPE OF WORK
SECTION 202 – REMOVAL OF STRUCTURES AND OBSTRUCTIONS
SECTION 203 – EXCAVATION AND EMBANKMENT
SECTION 604 – SIDEWALKS, CURB RAMPS, STEPS, AND HANDRAILS
SECTION 619 – COATING BRIDGE STEEL
SECTION 711 – STEEL STRUCTURES
SECTION 712 – TIMBER STRUCTURES
SECTION 729 – HEAT STRAIGHTENING OF STEEL MEMBERS IN THE FIELD
SECTION 801 – TRAFFIC CONTROLS FOR CONSTRUCTION AND MAINTENANCE OPERATIONS
SECTION 802 – SIGNS
SECTION 805 – TRAFFIC SIGNALS
SECTION 807 – HIGHWAY ILLUMINATION
SECTION 909 – COATINGS, PAINTS, AND LIQUID EPOXY
619-B-314 ALTERNATE FINISH COAT FOR PARTIAL PAINT SYSTEM (PROPOSED TO DISCONTINUE)
620-R-483 SOUND BARRIER SYSTEMS

The structural design of the sound barrier system shall be in accordance with the AASHTO LRFD Bridge Design Specifications, except as otherwise directed.

The post spacing for sound barriers mounted on any structure or safety barrier shall be limited to a distance that does not overstress the structure or safety barrier. The spacing shall also be limited to a distance that allows the sound barrier to conform to the existing horizontal and vertical alignments. The allowable loads on a structure or barrier shall be as shown on the plans. If no allowable loads are shown, the allowable loads on a sound barrier shall be in accordance with the AASHTO LRFD Bridge Design Specifications.

When sound barriers are to be installed on a bridge structure, design calculations shall be submitted to the Engineer that demonstrate structure loading limits will not be exceeded.

All materials shall have a minimum predicted maintenance free structural and acoustical lifespan of 20 years. All colorings and coatings shall have a minimum predicted maintenance free lifespan of 10 years.

The types of acoustic sound barrier systems that are accepted are as follows:

Type 1, single sided absorptive, sound barrier systems and their components shall be designed to achieve a sound transmission loss equal to or greater than 20 decibels at all frequencies when tested in accordance with ASTM E90. Type 1 sound barrier systems shall be designed to have a minimum noise reduction coefficient of 0.70 on the roadway side. Type 1 sound barrier systems shall be tested in accordance with ASTM C423. Material samples for this test shall be provided with the coating applied, so as to determine that the color coating does not inhibit the acoustic performance. The sample shall be mounted in accordance with ASTM E795, type A.

Type 2, double-sided absorptive, sound barrier systems and their components shall be designed to achieve a sound transmission loss equal to or greater than 20 decibels at all frequencies when tested in accordance with ASTM E90. Type 2 sound barrier systems

REVISION TO STANDARD SPECIFICATIONS AND SPECIAL PROVISIONS

SECTION 101 – DEFINITIONS AND TERMS
 SECTION 104 – SCOPE OF WORK
 SECTION 202 – REMOVAL OF STRUCTURES AND OBSTRUCTIONS
 SECTION 203 – EXCAVATION AND EMBANKMENT
 SECTION 604 – SIDEWALKS, CURB RAMPS, STEPS, AND HANDRAILS
 SECTION 619 – COATING BRIDGE STEEL
 SECTION 711 – STEEL STRUCTURES
 SECTION 712 – TIMBER STRUCTURES
 SECTION 729 – HEAT STRAIGHTENING OF STEEL MEMBERS IN THE FIELD
 SECTION 801 – TRAFFIC CONTROLS FOR CONSTRUCTION AND MAINTENANCE OPERATIONS
 SECTION 802 – SIGNS
 SECTION 805 – TRAFFIC SIGNALS
 SECTION 807 – HIGHWAY ILLUMINATION
 SECTION 909 – COATINGS, PAINTS, AND LIQUID EPOXY
 619-B-314 ALTERNATE FINISH COAT FOR PARTIAL PAINT SYSTEM (PROPOSED TO DISCONTINUE)
 620-R-483 SOUND BARRIER SYSTEMS

shall be designed to have a minimum noise reduction coefficient of 0.70 on the roadway and non-roadway sides. Type 2 sound barrier systems shall be tested in accordance with ASTM C423. To determine that the color coating does not inhibit the acoustic performance, material samples for this test shall be provided with the coating applied. The sample shall be mounted in accordance with ASTM E795, type A.

Type 3, reflective, sound barrier systems and their components shall be designed to achieve a sound transmission loss equal to or greater than 20 decibels at all frequencies when tested in accordance with ASTM E90.

A type 2 barrier system may be substituted for a type 1 barrier system at the Contractor's discretion. A type 1 or a type 2 barrier system may be substituted, with written approval, for a type 3 barrier system.

All molded finishes shall have a 1 in. minimum relief. All rolled finishes shall have a minimum 3/4 in. relief. Relief is defined by material that is provided in excess of the minimum wall thickness required to meet the Noise Reduction Coefficient required for the absorptive surfaces. Fluted finishes shall be coped at each end to avoid cracking.

Corrugations, ribs, or battens on sound barrier panels shall be oriented vertically when erected. The sound barrier shall be designed to prevent entrapment and ponding of water. The sound barrier shall not be designed with openings promoting the perching or nesting of birds, or the collection of dirt, debris, or water. The sound barrier shall not be designed with hand holds or grips promoting scaling or climbing of the system.

When shown on the plans, fire hydrant access points shall be included in the sound barrier and designed with additional reinforcement or bracing and protective coating around the opening as necessary to maintain structural integrity.

Closure plates shall be provided where new sound barrier is constructed adjacent to existing sound barrier. Where bridge mounted walls cross over expansion joints, expansion closure plates shall be used. The wall manufacturer shall provide expansion closure plates for each expansion joint unless directed otherwise. The minimum thickness of closure plates shall be 3/16 in.

REVISION TO STANDARD SPECIFICATIONS AND SPECIAL PROVISIONS

SECTION 101 – DEFINITIONS AND TERMS
 SECTION 104 – SCOPE OF WORK
 SECTION 202 – REMOVAL OF STRUCTURES AND OBSTRUCTIONS
 SECTION 203 – EXCAVATION AND EMBANKMENT
 SECTION 604 – SIDEWALKS, CURB RAMPS, STEPS, AND HANDRAILS
 SECTION 619 – COATING BRIDGE STEEL
 SECTION 711 – STEEL STRUCTURES
 SECTION 712 – TIMBER STRUCTURES
 SECTION 729 – HEAT STRAIGHTENING OF STEEL MEMBERS IN THE FIELD
 SECTION 801 – TRAFFIC CONTROLS FOR CONSTRUCTION AND MAINTENANCE OPERATIONS
 SECTION 802 – SIGNS
 SECTION 805 – TRAFFIC SIGNALS
 SECTION 807 – HIGHWAY ILLUMINATION
 SECTION 909 – COATINGS, PAINTS, AND LIQUID EPOXY
 619-B-314 ALTERNATE FINISH COAT FOR PARTIAL PAINT SYSTEM (PROPOSED TO DISCONTINUE)
 620-R-483 SOUND BARRIER SYSTEMS

The calculations for sound barriers which also retain earth shall show that the walls are adequate for earth retention. The earth retention areas shall be shown on the plans. The exposed face of the sound barrier earth retaining panel shall match the adjacent panel's color and texture.

(a) Precast Panel Design Criteria

Base-plated or embedded reinforced precast concrete posts may be substituted for wide flanged steel posts with the approval of the Department. Proposed substitutions for wide flanged steel posts shall be shown on working drawings submitted for approval.

Support posts shall match the adjoining wall in color unless directed by the Engineer. Embedded reinforced precast concrete posts shall also match the adjoining wall in texture. Sound barrier systems utilizing stacked panels shall have ship-lapped or tongue and groove horizontal joints or other approved design which blocks the passage of light.

(b) Masonry Design Criteria

Reinforced masonry vertical support posts shall be faced to match the adjoining wall in color and texture unless directed by the Engineer.

Steel support posts shall match the adjoining wall in color unless directed by the Engineer.

620.03 Submittals

The Contractor shall submit a minimum of three alternative textured finishes for the wall to the Engineer. These shall include the following colors:

- (a) light gray (SAE-AMS STD 595, color No. 36492),*
- (b) light brown (SAE-AMS STD 595, color No. 30450),*
- (c) light tan (SAE-AMS STD 595, color No. 37769).*

The colors will be presented to the public for their input in accordance with 620.05. The final wall pattern and color will be approved before production of the wall panels may begin.

REVISION TO STANDARD SPECIFICATIONS AND SPECIAL PROVISIONS

SECTION 101 – DEFINITIONS AND TERMS
SECTION 104 – SCOPE OF WORK
SECTION 202 – REMOVAL OF STRUCTURES AND OBSTRUCTIONS
SECTION 203 – EXCAVATION AND EMBANKMENT
SECTION 604 – SIDEWALKS, CURB RAMPS, STEPS, AND HANDRAILS
SECTION 619 – COATING BRIDGE STEEL
SECTION 711 – STEEL STRUCTURES
SECTION 712 – TIMBER STRUCTURES
SECTION 729 – HEAT STRAIGHTENING OF STEEL MEMBERS IN THE FIELD
SECTION 801 – TRAFFIC CONTROLS FOR CONSTRUCTION AND MAINTENANCE OPERATIONS
SECTION 802 – SIGNS
SECTION 805 – TRAFFIC SIGNALS
SECTION 807 – HIGHWAY ILLUMINATION
SECTION 909 – COATINGS, PAINTS, AND LIQUID EPOXY
619-B-314 ALTERNATE FINISH COAT FOR PARTIAL PAINT SYSTEM (PROPOSED TO DISCONTINUE)
620-R-483 SOUND BARRIER SYSTEMS

The Contractor shall submit design calculations in accordance with 105.02. Calculations for sound barriers on bridge structures shall include an analysis of the bridge structure that demonstrates the additional loads imposed by the sound barrier, in accordance with the AASHTO LRFD Bridge Design Specifications, will not exceed the structural capacity of the bridge. The Contractor shall submit working drawings in accordance with 105.02 after design calculations are approved and before beginning wall construction operations. Design calculations and working drawings shall meet the following minimum requirements:

- (a) Design calculations shall include all structural design calculations and vertical support post design calculations.*
- (b) Design calculations for bridge mounted installations shall include the design unit weight and mass of the sound barrier and support systems.*
- (c) Design calculations for bridge mounted installations shall demonstrate that the structural loading limits of the structure will not be exceeded.*
- (d) Working drawings shall include all details, dimensions, quantities, and cross sections necessary to construct the sound barrier systems and shall include but not be limited to the following:*
 - 1. A plan and elevation sheet or sheets for each sound barrier systems location.*
 - 2. An elevation view of the sound barrier systems which shall include the elevation at the top of the wall at all horizontal and vertical break points at least every 50 ft along the face of the wall.*
 - 3. A plan view of the wall that indicates the offsets from the construction centerline to the face of the wall at all changes in horizontal alignment. A plan view and elevation view which detail the placing position.*

REVISION TO STANDARD SPECIFICATIONS AND SPECIAL PROVISIONS

- SECTION 101 – DEFINITIONS AND TERMS
- SECTION 104 – SCOPE OF WORK
- SECTION 202 – REMOVAL OF STRUCTURES AND OBSTRUCTIONS
- SECTION 203 – EXCAVATION AND EMBANKMENT
- SECTION 604 – SIDEWALKS, CURB RAMPS, STEPS, AND HANDRAILS
- SECTION 619 – COATING BRIDGE STEEL
- SECTION 711 – STEEL STRUCTURES
- SECTION 712 – TIMBER STRUCTURES
- SECTION 729 – HEAT STRAIGHTENING OF STEEL MEMBERS IN THE FIELD
- SECTION 801 – TRAFFIC CONTROLS FOR CONSTRUCTION AND MAINTENANCE OPERATIONS
- SECTION 802 – SIGNS
- SECTION 805 – TRAFFIC SIGNALS
- SECTION 807 – HIGHWAY ILLUMINATION
- SECTION 909 – COATINGS, PAINTS, AND LIQUID EPOXY
- 619-B-314 ALTERNATE FINISH COAT FOR PARTIAL PAINT SYSTEM (PROPOSED TO DISCONTINUE)
- 620-R-483 SOUND BARRIER SYSTEMS

4. *A typical cross-section or cross-sections showing elevation relationship between ground conditions and the sound barrier systems locations.*
 5. *All general notes required for constructing the wall.*
 6. *Each sheet shall show the complete project identification number.*
 7. *All horizontal and vertical curve data affecting the wall.*
 8. *A listing of the summary of quantities on the elevation sheet for each wall.*
 9. *A list of manufacturer’s recommendations with respect to maintenance, including repair of graffiti and other damages.*
 10. *Typical sections, connection details, and elevation views for bridge mounted installations.*
- (e) *Working drawings shall include a detailed plan of aesthetic treatment for the entire sound barrier system, manufacturer-recommended installation requirements and sequence of construction, manufacturer-recommended repair requirements for damage caused by vandalism or graffiti prior to final acceptance, and a detailed bill of materials.*

MATERIALS

620.04 Materials

Materials shall be in accordance with the following:

<i>Cast-in-Place Portland Cement Concrete, Class A</i>	<i>702</i>
<i>Coarse Aggregate, Class A or Higher, Size No. 91</i>	<i>904.03</i>
<i>Coarse Aggregate, Class D or Higher, Size No. 2</i>	<i>904.03</i>
<i>Concrete Masonry Units</i>	<i>905.06</i>

REVISION TO STANDARD SPECIFICATIONS AND SPECIAL PROVISIONS

- SECTION 101 – DEFINITIONS AND TERMS
- SECTION 104 – SCOPE OF WORK
- SECTION 202 – REMOVAL OF STRUCTURES AND OBSTRUCTIONS
- SECTION 203 – EXCAVATION AND EMBANKMENT
- SECTION 604 – SIDEWALKS, CURB RAMPS, STEPS, AND HANDRAILS
- SECTION 619 – COATING BRIDGE STEEL
- SECTION 711 – STEEL STRUCTURES
- SECTION 712 – TIMBER STRUCTURES
- SECTION 729 – HEAT STRAIGHTENING OF STEEL MEMBERS IN THE FIELD
- SECTION 801 – TRAFFIC CONTROLS FOR CONSTRUCTION AND MAINTENANCE OPERATIONS
- SECTION 802 – SIGNS
- SECTION 805 – TRAFFIC SIGNALS
- SECTION 807 – HIGHWAY ILLUMINATION
- SECTION 909 – COATINGS, PAINTS, AND LIQUID EPOXY
- 619-B-314 ALTERNATE FINISH COAT FOR PARTIAL PAINT SYSTEM (PROPOSED TO DISCONTINUE)
- 620-R-483 SOUND BARRIER SYSTEMS

<i>Fine Aggregate, Size No. 23</i>	904.02
<i>Joint Mortar</i>	901.08, 907.12
Paint Coatings for Metal.....	909.02
<i>Portland Cement</i>	901.01(b)
<i>Precast Concrete</i>	707
<i>Reinforcing Bars</i>	910.01
<i>Structural Aluminum Posts</i>	910.14(d)
<i>Structural Steel</i>	910
<i>Water</i>	913.01

Structural steel components shall be hot dipped galvanized in accordance with ASTM A123, coating grade 100 or painted with a coating in accordance with 619.11 and 619.12 with the exception that the finish coat shall be a waterborne acrylic ~~paint~~coating in one of the colors listed below and otherwise in accordance with 909.02(e). ~~If hot dipped, the galvanized surfaces shall be prepared using a light brush-off blast cleaning in accordance with SSPC-SP16. The surface profile shall be 15 to 30 microns in accordance with ASTM D4417, prior to painting.~~

Exposed surfaces of galvanized components shall be ~~painted~~prepared using a light brush-off blast cleaning in accordance with SSPC-SP16. The surface profile shall be 15 to 30 microns in accordance with ASTM D4417, prior to coating. The coating shall be in accordance with 619.09(b), 909.02, and the following.

In lieu of the properties listed in 909.02(d)3, the waterborne finish ~~paint~~coat mixed ~~paint~~coating properties shall be in accordance with the following requirements.

<i>Weight/volume, ASTM D1475, 25°C, min.</i>	1.200 kg/L
<i>Total solids, % by weight, ASTM D2369, min.</i>	48
<i>Volatile organic compounds, ASTM D3960, max.</i>	180 g/L
<i>Specular gloss, 60°, 10 ±0.5 mils wet film thickness on a tin coated steel panel, dried 48 h, ASTM D523, max.</i>	25

The color of the dried ~~paint~~film shall match the color of the sound barrier panels

REVISION TO STANDARD SPECIFICATIONS AND SPECIAL PROVISIONS

SECTION 101 – DEFINITIONS AND TERMS
 SECTION 104 – SCOPE OF WORK
 SECTION 202 – REMOVAL OF STRUCTURES AND OBSTRUCTIONS
 SECTION 203 – EXCAVATION AND EMBANKMENT
 SECTION 604 – SIDEWALKS, CURB RAMPS, STEPS, AND HANDRAILS
 SECTION 619 – COATING BRIDGE STEEL
 SECTION 711 – STEEL STRUCTURES
 SECTION 712 – TIMBER STRUCTURES
 SECTION 729 – HEAT STRAIGHTENING OF STEEL MEMBERS IN THE FIELD
 SECTION 801 – TRAFFIC CONTROLS FOR CONSTRUCTION AND MAINTENANCE OPERATIONS
 SECTION 802 – SIGNS
 SECTION 805 – TRAFFIC SIGNALS
 SECTION 807 – HIGHWAY ILLUMINATION
 SECTION 909 – COATINGS, PAINTS, AND LIQUID EPOXY
 619-B-314 ALTERNATE FINISH COAT FOR PARTIAL PAINT SYSTEM (PROPOSED TO DISCONTINUE)
 620-R-483 SOUND BARRIER SYSTEMS

- (a) light gray (SAE-AMS-STD-595, color No. 26492),
 - (b) light brown (SAE-AMS-STD-595, color No. 20450),
 - (c) light tan (SAE-AMS-STD-595, color No. 27769),
- unless otherwise shown on the plans.

All structural steel hardware shall be in accordance with ASTM F3125, Grade A 325 and shall be hot-dipped galvanized in accordance with ASTM F2329 or shall be made of nonferrous material or stainless steel. All other non-structural fastening devices shall be made of nonferrous metal or stainless steel. Plastic members shall be connected with either screws or bolts. Aluminum members shall be connected with stainless steel fasteners. Anchor bolts shall be of the size shown with a minimum of 10 in. of 7NC threads on the upper end. Anchor bolts shall be in accordance with ASTM F1554. The threads, nuts, and washers shall be galvanized in accordance with ASTM F2329 or be mechanically galvanized and conform to the coating thickness, adherence, and quality requirements of ASTM B695, Class 55.

Solid portland cement concrete or composite concrete shall be coated or contain an integral pigment, as specified by the manufacturer, and shall meet the specified color requirements. Integral pigment shall be certified to be in accordance with ASTM C979. The coating shall be tested for accelerated weathering in accordance with ASTM D6695. The test panel substrate shall be of the same portland cement concrete or composite concrete material used in the sound barrier system component. Cured coating or integral pigment shall not contain heavy metals that exceed the requirements of 40 CFR 261.24.

Concrete class A for the coping shall be in accordance with the applicable requirements of 702, except the coarse aggregate for pre-cast units may be size No. 91 in accordance with 904. Reinforcing steel in the coping shall be in accordance with the applicable requirements of 703. The coping may be precast or cast-in-place.

Masonry block shall be tested in accordance with ASTM C90 and as follows:

- (a) *The average compressive strength of three units shall be a minimum of 3,000 psi with no single unit being less than 2,700 psi.*

REVISION TO STANDARD SPECIFICATIONS AND SPECIAL PROVISIONS

SECTION 101 – DEFINITIONS AND TERMS
 SECTION 104 – SCOPE OF WORK
 SECTION 202 – REMOVAL OF STRUCTURES AND OBSTRUCTIONS
 SECTION 203 – EXCAVATION AND EMBANKMENT
 SECTION 604 – SIDEWALKS, CURB RAMPS, STEPS, AND HANDRAILS
 SECTION 619 – COATING BRIDGE STEEL
 SECTION 711 – STEEL STRUCTURES
 SECTION 712 – TIMBER STRUCTURES
 SECTION 729 – HEAT STRAIGHTENING OF STEEL MEMBERS IN THE FIELD
 SECTION 801 – TRAFFIC CONTROLS FOR CONSTRUCTION AND MAINTENANCE OPERATIONS
 SECTION 802 – SIGNS
 SECTION 805 – TRAFFIC SIGNALS
 SECTION 807 – HIGHWAY ILLUMINATION
 SECTION 909 – COATINGS, PAINTS, AND LIQUID EPOXY
 619-B-314 ALTERNATE FINISH COAT FOR PARTIAL PAINT SYSTEM (PROPOSED TO DISCONTINUE)
 620-R-483 SOUND BARRIER SYSTEMS

- (b) *The units shall be tested for water absorption in accordance with ASTM C140. The maximum absorption shall be 7%.*
- (c) *Joint reinforcement for masonry block systems shall be in accordance with ASTM A951.*
- (d) *Mortar for masonry block systems shall be in accordance with ASTM C270; type S, Table 2 proportion requirements.*
- (e) *Portland cement-lime or mortar cement may be used. Masonry cement shall not be used. Grout for masonry shall be in accordance with ASTM C476.*
- (f) *Aggregate for masonry grout shall be in accordance with ASTM C404.*

Masonry blocks shall be coated or contain an integral pigment, as specified by the manufacturer, and shall meet the specified color requirements. The integral pigment shall be certified to be in accordance with ASTM C979. The coating shall be tested for accelerated weathering in accordance with ASTM D6695. The test panel substrate shall be of the same masonry blocks used in the sound barrier system component. Cured coating or integral pigment shall not contain heavy metals that exceed the requirements of 40 CFR 261.24.

Certifications shall be provided for each of the materials to be supplied for the sound barrier system. A type C certification in accordance with 916 shall be provided for the sound barrier materials, unless otherwise noted. A type A certification in accordance with 916 shall be provided for compressive strength and absorption test values for masonry block, sampled and tested in accordance with ASTM C140. All test reports required to substantiate compliance shall be in accordance with the test method/material requirements cited herein. A Department approved laboratory shall conduct the testing.

CONSTRUCTION REQUIREMENTS

620.05 Information for Public Input

Colored flyers with appropriate graphics shall be developed by the Contractor and

REVISION TO STANDARD SPECIFICATIONS AND SPECIAL PROVISIONS

SECTION 101 – DEFINITIONS AND TERMS
 SECTION 104 – SCOPE OF WORK
 SECTION 202 – REMOVAL OF STRUCTURES AND OBSTRUCTIONS
 SECTION 203 – EXCAVATION AND EMBANKMENT
 SECTION 604 – SIDEWALKS, CURB RAMPS, STEPS, AND HANDRAILS
 SECTION 619 – COATING BRIDGE STEEL
 SECTION 711 – STEEL STRUCTURES
 SECTION 712 – TIMBER STRUCTURES
 SECTION 729 – HEAT STRAIGHTENING OF STEEL MEMBERS IN THE FIELD
 SECTION 801 – TRAFFIC CONTROLS FOR CONSTRUCTION AND MAINTENANCE OPERATIONS
 SECTION 802 – SIGNS
 SECTION 805 – TRAFFIC SIGNALS
 SECTION 807 – HIGHWAY ILLUMINATION
 SECTION 909 – COATINGS, PAINTS, AND LIQUID EPOXY
 619-B-314 ALTERNATE FINISH COAT FOR PARTIAL PAINT SYSTEM (PROPOSED TO DISCONTINUE)
 620-R-483 SOUND BARRIER SYSTEMS

furnished to the Department.

Wall color photos shall be provided for each color in accordance with 620.03 along with photos of each available texture alternative. A minimum of three wall samples of the non-roadway side textures shall be provided. All samples of the wall textures shall be a minimum of 3 sq ft in area, with a distinguishable pattern.

Based on comments received, the Department will select the final finishes and colors for each wall. Each wall shall have the selected color used throughout the entire wall on the roadway and the non-roadway sides. The Contractor shall coordinate all sound barrier wall issues with the Engineer prior to ordering any materials.

620.06 Construction Requirements

Sound barrier components shall not be stored on the right-of-way unless written permission is given by the Department. Requests for permission to store materials on the right-of-way will not be accepted until after the contract has been awarded.

The sound barrier supplier shall provide technical instruction, guidance in preconstruction activities including the preconstruction conference, and on-site technical assistance during construction. The Contractor is responsible for following installing instructions from the supplier unless otherwise directed in writing by the Engineer.

Clearing and grading shall be in accordance with 201 and 202 as required.

The foundations for ground mounted sound barrier systems shall be constructed as shown on the working drawings. Holes for footings shall be drained of free water prior to installing any components. Placing concrete shall be in accordance with 702.

The integrity of the sound barrier system continuity shall be such that no light will be visible through any vertical joint between sound barrier panel and vertical support post, through any horizontal joint between sound barrier panels, between the bottom of any ground mounted sound barrier and the adjacent ground, or between the bottom of any wall mounted sound barrier and the top of the adjacent wall. Exceptions may be allowed as necessary for drainage as indicated on the plans.

REVISION TO STANDARD SPECIFICATIONS AND SPECIAL PROVISIONS

SECTION 101 – DEFINITIONS AND TERMS
 SECTION 104 – SCOPE OF WORK
 SECTION 202 – REMOVAL OF STRUCTURES AND OBSTRUCTIONS
 SECTION 203 – EXCAVATION AND EMBANKMENT
 SECTION 604 – SIDEWALKS, CURB RAMPS, STEPS, AND HANDRAILS
 SECTION 619 – COATING BRIDGE STEEL
 SECTION 711 – STEEL STRUCTURES
 SECTION 712 – TIMBER STRUCTURES
 SECTION 729 – HEAT STRAIGHTENING OF STEEL MEMBERS IN THE FIELD
 SECTION 801 – TRAFFIC CONTROLS FOR CONSTRUCTION AND MAINTENANCE OPERATIONS
 SECTION 802 – SIGNS
 SECTION 805 – TRAFFIC SIGNALS
 SECTION 807 – HIGHWAY ILLUMINATION
 SECTION 909 – COATINGS, PAINTS, AND LIQUID EPOXY
 619-B-314 ALTERNATE FINISH COAT FOR PARTIAL PAINT SYSTEM (PROPOSED TO DISCONTINUE)
 620-R-483 SOUND BARRIER SYSTEMS

Sound barrier wall posts shall be placed vertical with a tolerance of 1/2 in. per 10 ft on each axis. Sound barrier wall posts shall be placed at the distance indicated on the plans with a tolerance of 1 in. from centerline to centerline. Sound barrier wall posts shall be aligned to within 1 in. when measured from a straight line from the two adjacent posts. Sound barrier wall posts shall be at the height as shown on the plans. The posts shall project above the top sound barrier wall panel by 1 1/2 in. $\pm 1/2$ in. The top of the sound barrier wall shall be at or above the acoustical profile. Steel posts embedded in concrete shall have bottom cover of 8 in. ± 4 in. Field-cut steel posts shall be primed with an organic zinc primer and ~~primed~~ coated in accordance with 619.

After post erection the area shall be backfilled to within 6 in. of the required final grade or as specified in the plans. The aggregate pad shall be placed as required. Positive drainage of the work area shall be maintained.

An aggregate pad of No. 2 coarse aggregate shall be included that extends 4 in. outside of each side of the panel and 4 in. below the bottom of the panel.

The sound barrier system and sound barrier system components shall be maintained until final acceptance. Elements of the sound barrier system that are damaged or destroyed, including due to graffiti or other vandalism, shall be repaired or replaced as directed by the Engineer. Repairs and repainting or recoating shall be conducted in accordance with the manufacturer's guidance and 620.02.

After construction of the sound barrier system the site shall be restored to the original condition with grading, seeding and sodding in accordance with the plans.

(a) Construction Requirements for Precast Panels

Sound barrier wall panels shall be placed in accordance with the plans and centered between adjacent posts. The sound barrier wall panels shall be of sufficient length to span the entire length between posts less 1/2 the width of the smallest retaining flange.

Panels may be field-cut to facilitate erection in accordance with the manufacturer's recommendation. Field-cut panels shall be cut to have the least impact on any patterns

REVISION TO STANDARD SPECIFICATIONS AND SPECIAL PROVISIONS

SECTION 101 – DEFINITIONS AND TERMS
 SECTION 104 – SCOPE OF WORK
 SECTION 202 – REMOVAL OF STRUCTURES AND OBSTRUCTIONS
 SECTION 203 – EXCAVATION AND EMBANKMENT
 SECTION 604 – SIDEWALKS, CURB RAMPS, STEPS, AND HANDRAILS
 SECTION 619 – COATING BRIDGE STEEL
 SECTION 711 – STEEL STRUCTURES
 SECTION 712 – TIMBER STRUCTURES
 SECTION 729 – HEAT STRAIGHTENING OF STEEL MEMBERS IN THE FIELD
 SECTION 801 – TRAFFIC CONTROLS FOR CONSTRUCTION AND MAINTENANCE OPERATIONS
 SECTION 802 – SIGNS
 SECTION 805 – TRAFFIC SIGNALS
 SECTION 807 – HIGHWAY ILLUMINATION
 SECTION 909 – COATINGS, PAINTS, AND LIQUID EPOXY
 619-B-314 ALTERNATE FINISH COAT FOR PARTIAL PAINT SYSTEM (PROPOSED TO DISCONTINUE)
 620-R-483 SOUND BARRIER SYSTEMS

present in the textured or colored finish. Field-cut panels or other field cut components shall be painted or coated in accordance with the manufacturer's guidance.

(b) Construction Requirements for Masonry

All grouting and reinforcing work for masonry block systems shall be performed by masonry craftworkers holding current International Masonry Institute, IMI, Grouting and Reinforcing Certification. Proof of certification shall be submitted prior to the beginning of work.

620.07 Acceptance

The Contractor shall submit 2 ft by 2 ft sound barrier panel samples or five masonry block units in the colors and textures proposed and a 2 ft sample of painted or coated support post, prior to the approval of the working plans. Once approved, these samples will be used as a control sample to verify delivered products meet the aesthetic requirements. The sound barrier system will be accepted for color based on a visual comparison between the control sample and the color of the wall as constructed in place.

The sound barrier system will be accepted for quality based on a visual inspection of the components of the system by the Engineer. The sound barrier system shall be subject to rejection due to failure to be in accordance with the requirements specified herein. In addition, the following defects may also be sufficient cause for rejection:

- (a) Defects that indicate imperfect fabrication*
- (b) Defects in physical appearance such as cracks, checks, dents, scrapes, chips, stains, or color variations.*

The Engineer will determine whether a defective sound barrier shall be repaired or shall be cause for rejection. Repair, if permitted, shall be completed by the Contractor and will be approved by the Engineer.

620.08 Method of Measurement

Sound barrier panels and sound barrier erection will be measured by the square foot of wall surface area. The pay quantity will be based on the limits of the sound barrier

REVISION TO STANDARD SPECIFICATIONS AND SPECIAL PROVISIONS

SECTION 101 – DEFINITIONS AND TERMS
 SECTION 104 – SCOPE OF WORK
 SECTION 202 – REMOVAL OF STRUCTURES AND OBSTRUCTIONS
 SECTION 203 – EXCAVATION AND EMBANKMENT
 SECTION 604 – SIDEWALKS, CURB RAMPS, STEPS, AND HANDRAILS
 SECTION 619 – COATING BRIDGE STEEL
 SECTION 711 – STEEL STRUCTURES
 SECTION 712 – TIMBER STRUCTURES
 SECTION 729 – HEAT STRAIGHTENING OF STEEL MEMBERS IN THE FIELD
 SECTION 801 – TRAFFIC CONTROLS FOR CONSTRUCTION AND MAINTENANCE OPERATIONS
 SECTION 802 – SIGNS
 SECTION 805 – TRAFFIC SIGNALS
 SECTION 807 – HIGHWAY ILLUMINATION
 SECTION 909 – COATINGS, PAINTS, AND LIQUID EPOXY
 619-B-314 ALTERNATE FINISH COAT FOR PARTIAL PAINT SYSTEM (PROPOSED TO DISCONTINUE)
 620-R-483 SOUND BARRIER SYSTEMS

envelope as shown on the plans. The vertical and horizontal distance for each section of the wall defines the sound barrier envelope. The vertical distance extends from the elevation at the bottom of the lowest panel to the elevation of the acoustic profile for each section of the wall. The horizontal distance extends from centerline to centerline of adjacent posts for each section of wall.

Coping will not be measured. Brackets required for the attachment of signs to the sound barrier will not be measured.

620.09 Basis of Payment

Wall mounted sound barrier panels, bridge mounted sound barrier panels, ground mounted sound barrier panels, wall mounted sound barrier erection, bridge mounted sound barrier erection, and ground mounted sound barrier erection will be paid for at the contract unit price per square foot.

The Department may choose to acquire additional precast sound wall panels or masonry blocks in the colors and patterns selected on the project. A maximum of 12 panels of each type would be paid for at the invoice cost of the panels and shall be delivered to the District Office. If the Department elects to acquire additional precast sound wall panels or masonry blocks, the Contractor shall provide the material as extra work in accordance with 104.03.

Partial payment will be made for sound barrier panels stockpiled on the project site or at the Contractor's approved storage location within the State of Indiana. Partial payment will be based on the delivered cost of the sound barrier panels, as verified by invoices that include freight charges. The Contractor shall furnish the invoices and all required certifications. Partial payment will not exceed 75% of the contract unit price for bridge mounted, ground mounted or wall mounted sound barrier panels. Prior to authorizing the partial payment, verification will be obtained that all required inspection has been made and that the panels are acceptable.

Payment for all costs associated with the collection of all information not shown on the plans, revisions due to conflicts, sound barrier system details, all additions or incidentals necessary to provide complete plans, any redesigning of plans or details, the

REVISION TO STANDARD SPECIFICATIONS AND SPECIAL PROVISIONS

- SECTION 101 – DEFINITIONS AND TERMS
- SECTION 104 – SCOPE OF WORK
- SECTION 202 – REMOVAL OF STRUCTURES AND OBSTRUCTIONS
- SECTION 203 – EXCAVATION AND EMBANKMENT
- SECTION 604 – SIDEWALKS, CURB RAMPS, STEPS, AND HANDRAILS
- SECTION 619 – COATING BRIDGE STEEL
- SECTION 711 – STEEL STRUCTURES
- SECTION 712 – TIMBER STRUCTURES
- SECTION 729 – HEAT STRAIGHTENING OF STEEL MEMBERS IN THE FIELD
- SECTION 801 – TRAFFIC CONTROLS FOR CONSTRUCTION AND MAINTENANCE OPERATIONS
- SECTION 802 – SIGNS
- SECTION 805 – TRAFFIC SIGNALS
- SECTION 807 – HIGHWAY ILLUMINATION
- SECTION 909 – COATINGS, PAINTS, AND LIQUID EPOXY
- 619-B-314 ALTERNATE FINISH COAT FOR PARTIAL PAINT SYSTEM (PROPOSED TO DISCONTINUE)
- 620-R-483 SOUND BARRIER SYSTEMS

public information meetings and public information planning and presentations will be paid for at the contract lump sum price for sound barrier design and layout.

Payment will be made under:

<i>Pay Item</i>	<i>Pay Unit Symbol</i>
<i>Sound Barrier Design and Layout</i>	<i>LS</i>
<i>Sound Barrier Erection, _____, _____</i>	<i>SFT</i>
<i>mounting type,* type**</i>	
<i>Sound Barrier Panels, _____, _____</i>	<i>SFT</i>
<i>mounting type,* type**</i>	

* *Mounting type of sound barrier system: bridge mounted (BM), ground mounted (GM), wall mounted (WM)*
 ** *Type 1, 2, or 3.*

The cost of sound barrier panel materials including vertical support posts, coping, aggregate pad, grout and joint reinforcement for masonry block, fasteners, closures, expansion plates, openings and incidentals shall be included in the cost of the sound barrier panels for the type of sound barrier panels.

The cost of designing, furnishing, and installing brackets for signs that attach to the sound barrier shall be included in the cost of the design and layout of the sound barrier panels.

Substituting Type 2 wall for Type 1 wall or substituting Type 1 or Type 2 wall for Type 3 wall shall be at no cost to the Department.

The cost of the selected texture and selected color shall be included in the cost of the sound barrier panel for the type of sound barrier panels.

The cost of all labor and materials to prepare and erect the sound barrier shall be included in the cost of sound barrier erection for the type of sound barrier panels.

REVISION TO STANDARD SPECIFICATIONS AND SPECIAL PROVISIONS

SECTION 101 – DEFINITIONS AND TERMS

SECTION 104 – SCOPE OF WORK

SECTION 202 – REMOVAL OF STRUCTURES AND OBSTRUCTIONS

SECTION 203 – EXCAVATION AND EMBANKMENT

SECTION 604 – SIDEWALKS, CURB RAMPS, STEPS, AND HANDRAILS

SECTION 619 – COATING BRIDGE STEEL

SECTION 711 – STEEL STRUCTURES

SECTION 712 – TIMBER STRUCTURES

SECTION 729 – HEAT STRAIGHTENING OF STEEL MEMBERS IN THE FIELD

SECTION 801 – TRAFFIC CONTROLS FOR CONSTRUCTION AND MAINTENANCE OPERATIONS

SECTION 802 – SIGNS

SECTION 805 – TRAFFIC SIGNALS

SECTION 807 – HIGHWAY ILLUMINATION

SECTION 909 – COATINGS, PAINTS, AND LIQUID EPOXY

619-B-314 ALTERNATE FINISH COAT FOR PARTIAL PAINT SYSTEM (PROPOSED TO DISCONTINUE)

620-R-483 SOUND BARRIER SYSTEMS

The cost of foundation preparation and construction with associated work shall be included in the cost of sound barrier, ground mounted.

The cost of removal or construction of concrete barrier walls is not included in the cost of sound barrier erection, wall mounted.

FINAL DRAFT MINUTES

COMMENTS AND ACTION

SECTION 101 – DEFINITIONS AND TERMS
SECTION 104 – SCOPE OF WORK
SECTION 202 – REMOVAL OF STRUCTURES AND OBSTRUCTIONS
SECTION 203 – EXCAVATION AND EMBANKMENT
SECTION 604 – SIDEWALKS, CURB RAMPS, STEPS, AND HANDRAILS
SECTION 619 – COATING BRIDGE STEEL
SECTION 711 – STEEL STRUCTURES
SECTION 712 – TIMBER STRUCTURES
SECTION 729 – HEAT STRAIGHTENING OF STEEL MEMBERS IN THE FIELD
SECTION 801 – TRAFFIC CONTROLS FOR CONSTRUCTION AND MAINTENANCE OPERATIONS
SECTION 802 – SIGNS
SECTION 805 – TRAFFIC SIGNALS
SECTION 807 – HIGHWAY ILLUMINATION
SECTION 909 – COATINGS, PAINTS, AND LIQUID EPOXY
619-B-314 ALTERNATE FINISH COAT FOR PARTIAL PAINT SYSTEM (PROPOSED TO DISCONTINUE)
620-R-483 SOUND BARRIER SYSTEMS

DISCUSSION:

This item was introduced and presented by Mr. Reilman who explained that typical industry nomenclature uses the term "coating" instead of paint as most of these products are not actually paints. Updates are needed to the Partial Paint System material products.

Mr. Reilman proposed to change the term "paint" to "coating" in most places in 619 and 909 as shown. Mr. Reilman also proposed to incorporate updates to the Partial Paint System and delete RSP 619-B-314. Other editorial cleanups are shown as well.

With regard to the revisions shown for 619.10(a), Mr. Koch stated we could easily accidently approve a cold weather application buried within an 'updated for the contract, although generic' QCP. What is an 'uncontrolled environment' as a containment tent may be deemed to control the environment? Can more deliberate language be considered? The QCP should still contain processes on how to deal with temp, dew, and humidity. Following much discussion, the language in 619.10(a) has been revised as shown above.

Further editorial revisions are as shown. Discussions concerning the pay items list will occur outside of the meeting. Mr. Reilman revised his motion, which was seconded by Mr. Koch.

There was no further discussion and this item passed as revised.

[continued on next page]

COMMENTS AND ACTION

SECTION 101 – DEFINITIONS AND TERMS
 SECTION 104 – SCOPE OF WORK
 SECTION 202 – REMOVAL OF STRUCTURES AND OBSTRUCTIONS
 SECTION 203 – EXCAVATION AND EMBANKMENT
 SECTION 604 – SIDEWALKS, CURB RAMPS, STEPS, AND HANDRAILS
 SECTION 619 – COATING BRIDGE STEEL
 SECTION 711 – STEEL STRUCTURES
 SECTION 712 – TIMBER STRUCTURES
 SECTION 729 – HEAT STRAIGHTENING OF STEEL MEMBERS IN THE FIELD
 SECTION 801 – TRAFFIC CONTROLS FOR CONSTRUCTION AND MAINTENANCE OPERATIONS
 SECTION 802 – SIGNS
 SECTION 805 – TRAFFIC SIGNALS
 SECTION 807 – HIGHWAY ILLUMINATION
 SECTION 909 – COATINGS, PAINTS, AND LIQUID EPOXY
 619-B-314 ALTERNATE FINISH COAT FOR PARTIAL PAINT SYSTEM (PROPOSED TO DISCONTINUE)
 620-R-483 SOUND BARRIER SYSTEMS

[continued]

	Action:
Motion: Mr. Reilman Second: Mr. Koch Ayes: 10 Nays: 0 FHWA Approval: YES	<input type="checkbox"/> Passed as Submitted <input checked="" type="checkbox"/> Passed as Revised <input type="checkbox"/> Withdrawn
2024 Standard Specifications Sections referenced and/or affected: (see proposal)	<input checked="" type="checkbox"/> 2026 Standard Specifications (619-B-321 only) <input checked="" type="checkbox"/> Revise Pay Items List <input type="checkbox"/> Notification to Designers if change is <u>not</u> addressed by RSP
Recurring Special Provisions or Plan Details: 619-B-314 ALTERNATE FINISH COAT FOR PARTIAL PAINT SYSTEM	<input checked="" type="checkbox"/> Create RSP (No. 619-B-321) Effective: December 1, 2023
620-R-483 SOUND BARRIER SYSTEMS	<input checked="" type="checkbox"/> Discontinue RSP (No. 619-B-314) Sunset: November 30, 2023
Standard Drawing affected: E 619-PRBE-01	<input checked="" type="checkbox"/> Revise RSP (No. 620-R-483) Effective: December 1, 2023
Design Manual Sections affected: TBD	<input type="checkbox"/> Standard Drawing E 619-PRWS-01 will be revised editorially: "paint" replaced with "coat" Effective:
GIFE Sections cross-references: Section 5	<input type="checkbox"/> Create RPD (No. __) Effective:
	<input checked="" type="checkbox"/> GIFE Update <input checked="" type="checkbox"/> Frequency Manual Update <input checked="" type="checkbox"/> SiteManager Update

PROPOSAL TO STANDARDS COMMITTEE

PROBLEM(S) ENCOUNTERED: Confusion exists in 509.05(g) with the process control part of the QCP. This was written generically to address all mix types and it isn't clear that some of the stated properties do not apply depending on which of the five different options the contractor chooses for their concrete mix. Confusion also exists in 509.14 with who is supplying manpower for concrete sampling.

PROPOSED SOLUTION: In section 509.14, the phrase "as appropriate for the mix" is used with reference to job control testing to imply that not all of the listed properties are applicable to all of the concrete mixes. Similar phrasing should be added to 509.05(g) to provide clarity. Edit 509.14 to clarify who is supplying manpower.

APPLICABLE STANDARD SPECIFICATIONS: 509

APPLICABLE STANDARD DRAWINGS: none

APPLICABLE DESIGN MANUAL SECTION: none

APPLICABLE SECTION OF GIFE: none

APPLICABLE RECURRING SPECIAL PROVISIONS: none

PAY ITEMS AFFECTED: none

APPLICABLE SUB-COMMITTEE ENDORSEMENT: Ad hoc: Nathan Butts, Mike Nelson, Jim Reilman

IF APPROVED AS RECURRING SPECIAL PROVISION OR PLAN DETAILS, PROPOSED BASIS FOR USE: All contracts with a 509 pay item.

IMPACT ANALYSIS (attach report):

Submitted By: Jim Reilman

Title: State Materials Engineer

Organization: INDOT

Phone Number: (317) 522-9692

Date: 7/6/23

IMPACT ANALYSIS REPORT CHECKLIST

Explain the business case as to why this item should be presented to the Standards Committee for approval. Answer the following questions with Yes, No or N/A.

Does this item appear in any other specification sections? No

Will approval of this item affect the Approved Materials List? No

Will this proposal improve:

Construction costs? N/A

Construction time? N/A

Customer satisfaction? N/A

Congestion/travel time? N/A

Ride quality? N/A

Will this proposal reduce operational costs or maintenance effort? N/A

Will this item improve safety:

For motorists? N/A

For construction workers? N/A

Will this proposal improve quality for:

Construction procedures/processes? Yes

Asset preservation? N/A

Design process? N/A

Will this change provide the contractor more flexibility? N/A

Will this proposal provide clarification for the Contractor and field personnel? Yes

Can this item improve/reduce the number of potential change orders? N/A

Is this proposal needed for compliance with:

Federal or State regulations? No

AASHTO or other design code? No

Is this item editorial? No

Provide any further information as to why this proposal should be placed on the Standards Committee meeting Agenda:

REVISION TO STANDARD SPECIFICATIONS

SECTION 509 - PORTLAND CEMENT CONCRETE PAVEMENT, PCCP, JOINT REPAIR
509.05 Quality Control Plan
509.14 Job Control

(Note: Proposed changes shown highlighted gray)

The Standard Specifications are revised as follows:

SECTION 509, BEGIN LINE 196, INSERT AS FOLLOWS:

- (g) Process control of the concrete shall address *the following concrete properties as appropriate for the mix*: sampling and testing for slump, relative yield, air content, water cementitious ratio, and temperature. The frequency of tests shall be the first batch of the day and not less than three times per day including the first. If volumetric batching of concrete is utilized, the yield will be checked as described in 722.05(a) at the beginning of the day and not less than two times per day including the first load from each mobile mixer. The QCP shall include details as to actions in response to test results.

SECTION 509, BEGIN LINE 551, DELETE AND INSERT AS FOLLOWS:

~~The labor necessary for concrete sampling shall be furnished as required by the Engineer.~~
If additional manpower for concrete sampling is deemed necessary by the Engineer, the Contractor shall furnish the additional labor. Testing for slump, air content, and relative yield, as appropriate for the mix, will be on the first batch of the day and a minimum of once per every 400 cu ft thereafter. Beams or cylinders will be made for evaluating the quality of the delivered mix at least once for every three days of production or whenever slump, relative yield, or air content are failing the upper limit. The beams or cylinders will be tested for compliance with strength requirements, at an age consistent with the mixtures intended use as defined in 509.04. Beams or cylinders for this purpose shall be cured in accordance with Section 10.1 of AASHTO T 23 and 505.01(a).

COMMENTS AND ACTION

509.05 Quality Control Plan
 509.14 Job Control

DISCUSSION:

This item was introduced and presented by Mr. Reilman who stated that some confusion exists in 509.05(g) with the process control part of the QCP. This was written generically to address all mix types and it isn't clear that some of the stated properties do not apply depending on which of the five different options the Contractor chooses for their concrete mix. Confusion also exists in 509.14 with who is supplying manpower for concrete sampling.

Mr. Reilman proposed, that since in 509.14, the phrase "as appropriate for the mix" is used with reference to job control testing to imply that not all of the listed properties are applicable to all of the concrete mixes, similar phrasing should be added to 509.05(g) to provide clarity. Mr. Reilman also proposed to edit 509.14 to clarify who is supplying the manpower.

There was no further discussion and this item passed as submitted.

<p>Motion: Mr. Reilman Second: Mr. Novak Ayes: 10 Nays: 0 FHWA Approval: YES</p>	<p>Action:</p> <p><input checked="" type="checkbox"/> Passed as Submitted <input type="checkbox"/> Passed as Revised <input type="checkbox"/> Withdrawn</p>
<p>2024 Standard Specifications Sections referenced and/or affected: 509.05 pg 475; 509.14 pg. 483.</p>	<p><input checked="" type="checkbox"/> 2026 Standard Specifications <input type="checkbox"/> Revise Pay Items List <input type="checkbox"/> Notification to Designers if change is <u>not</u> addressed by RSP</p>
<p>Recurring Special Provisions or Plan Details: NONE</p>	<p><input checked="" type="checkbox"/> Create RSP (No. 509-R-763) Effective: December 1, 2023</p>
<p>Standard Drawing affected: NONE</p>	<p><input type="checkbox"/> Revise RSP (No. __) Effective:</p>
<p>Design Manual Sections affected: NONE</p>	<p><input type="checkbox"/> Standard Drawing Effective:</p>
<p>GIFE Sections cross-references: NONE</p>	<p><input type="checkbox"/> Create RPD (No. __) Effective:</p> <p><input type="checkbox"/> GIFE Update <input type="checkbox"/> Frequency Manual Update <input type="checkbox"/> SiteManager Update</p>

PROPOSAL TO STANDARDS COMMITTEE

PROBLEM(S) ENCOUNTERED: One of the three material options listed for roadway drain casting extensions is not available. To get back to the original intent of having three different allowable materials, a change is needed.

PROPOSED SOLUTION: Change the requirement for the plastic pipe from that stated (smooth wall PVC) to PVC pipe in accordance with 907.24(b).

APPLICABLE STANDARD SPECIFICATIONS: 715.02(i), 715.02(l), 907.16, 907.24(b)

APPLICABLE STANDARD DRAWINGS: none

APPLICABLE DESIGN MANUAL SECTION: none

APPLICABLE SECTION OF GIFE: none

APPLICABLE RECURRING SPECIAL PROVISIONS: none

PAY ITEMS AFFECTED: none

APPLICABLE SUB-COMMITTEE ENDORSEMENT:

IF APPROVED AS RECURRING SPECIAL PROVISION OR PLAN DETAILS, PROPOSED BASIS FOR USE: All contracts with a 715-10238 Pipe, Roadway Drain Casting Extension pay item.

IMPACT ANALYSIS (attach report):

Submitted By: Jim Reilman

Title: State Materials Engineer

Organization: INDOT

Phone Number: (317) 522-9692

Date: 7/6/23

IMPACT ANALYSIS REPORT CHECKLIST

Explain the business case as to why this item should be presented to the Standards Committee for approval. Answer the following questions with Yes, No or N/A.

Does this item appear in any other specification sections? No

Will approval of this item affect the Approved Materials List? No

Will this proposal improve:

Construction costs? N/A

Construction time? Yes

Customer satisfaction? Yes

Congestion/travel time? N/A

Ride quality? N/A

Will this proposal reduce operational costs or maintenance effort? N/A

Will this item improve safety:

For motorists? N/A

For construction workers? N/A

Will this proposal improve quality for:

Construction procedures/processes? N/A

Asset preservation? N/A

Design process? N/A

Will this change provide the contractor more flexibility? Yes

Will this proposal provide clarification for the Contractor and field personnel? Yes

Can this item improve/reduce the number of potential change orders? N/A

Is this proposal needed for compliance with:

Federal or State regulations? No

AASHTO or other design code? No

Is this item editorial? No

Provide any further information as to why this proposal should be placed on the Standards Committee meeting Agenda:

REVISION TO STANDARD SPECIFICATIONS

SECTION 715 – PIPE CULVERTS, AND STORM AND SANITARY SEWERS

715.02(i) Underdrain Outlet Pipe

715.02(l) Roadway Drain Casting Extensions

SECTION 907 – CONCRETE, CLAY, AND PLASTIC DRAINAGE COMPONENTS

907.16 Thermoplastic Pipe Requirements

907.24(b) Schedule 40 PVC Pipe

(Note: Proposed changes shown highlighted gray)

The Standard Specifications are revised as follows:

SECTION 715, BEGIN LINE 142, INSERT AS FOLLOWS:

(i) Underdrain Outlet Pipe

Pipe for underdrain outlets and drain tile outlets shall be PSM PVC pipe, profile wall PVC pipe, smooth wall polyethylene pipe, or smooth wall PVC pipe from the QPL of Thermoplastic Pipe and Liner Pipe Sources in accordance with 907.16 and 907.24. Schedule 40 PVC pipe in accordance with 907.24(b) is also allowable.

SECTION 715, BEGIN LINE 165, DELETE AND INSERT AS FOLLOWS:

(l) Roadway Drain Casting Extensions

Pipe used for extending roadway drain castings located in a bridge deck shall be in accordance with ~~907.23~~907.24(b), 907.28, or 908.10. Pipe support brackets and all hardware shall be galvanized in accordance with ASTM A153, class D or ASTM B695, class 40, type I. A Type C certification in accordance with 916 shall be provided for the pipe brackets.

SECTION 907, BEGIN LINE 216, DELETE AND INSERT AS FOLLOWS:

907.16 Thermoplastic Pipe Requirements

A QPL of thermoplastic pipe and liner pipe will be maintained by the Department. The QPL will specify the manufacturer and thermoplastic pipe designation. All of these materials shall comply with the applicable AASHTO or ASTM requirements listed in the following table and will only be accepted from qualified manufacturers. The manufacturer is defined as the plant which produces the thermoplastic pipe. The manufacturer shall become qualified by establishing a history of satisfactory quality control of these materials as evidenced by the test results performed by the manufacturer's testing laboratory.

Summary of Thermoplastic Pipe Specification Requirements				
Pipe Material	Standard Specification	AASHTO	ASTM	Manufacturer Requirement
Corrugated Polyethylene Drainage Tubing	907.17(a)	M 252		ITM 806, Procedure O
Corrugated Polyethylene Pipe	907.17(b)	M 294*		ITM 806, Procedure O
Corrugated Polypropylene Pipe	907.19	M 330		ITM 806, Procedure O
Perforated PVC Semicircular Pipe	907.18		D3034	ITM 806, Procedure A
Profile Wall HDPE Liner Pipe	907.25(b)		F894	ITM 806, Procedure A or 916, Type A Certification

REVISION TO STANDARD SPECIFICATIONS

SECTION 715 – PIPE CULVERTS, AND STORM AND SANITARY SEWERS

715.02(i) Underdrain Outlet Pipe

715.02(l) Roadway Drain Casting Extensions

SECTION 907 – CONCRETE, CLAY, AND PLASTIC DRAINAGE COMPONENTS

907.16 Thermoplastic Pipe Requirements

907.24(b) Schedule 40 PVC Pipe

Profile Wall PVC Liner Pipe	907.25(c)		F949	ITM 806, Procedure A or 916, Type A Certification
Profile Wall PVC Pipe	907.22 907.24(c)	M 304		ITM 806, Procedure O
Profile Wall Polyethylene Pipe	907.20		F894	ITM 806, Procedure A
Schedule 40 PVC Plastic Pipe, Schedule 40	907.24(b)		D1785 or D2665	916, Type C Certification
Smooth Wall Polyethylene Pipe	907.21 907.24(d)		F714	ITM 806, Procedure A
Smooth Wall PVC Pipe	907.23 907.24(e)	M 278	F679	ITM 806, Procedure A
Solid Wall HDPE Liner Pipe	907.25(a)		F714	ITM 806, Procedure Q or 916, Type A Certification
Type PSM PVC Pipe and Fittings	907.24(a)		D3034	ITM 806, Procedure A
* Pipe in accordance with AASHTO M 294 shall be manufactured with virgin materials.				

SECTION 907, BEGIN LINE 291, DELETE AND INSERT AS FOLLOWS:

(b) Schedule 40 PVC Plastic Pipe, Schedule 40

~~Pipe~~ PVC plastic pipe shall be in accordance with ASTM D1785 ~~when Schedule 40 is specified or D2665~~ and shall have a minimum pipe stiffness of 150 psi at 5% deflection when determined in accordance with ASTM D2412. Material furnished under this specification shall reference ASTM D1785 ~~or ASTM D2665~~ in the product print line. A Type C certification in accordance with 916 shall be provided for the ~~s~~ Schedule 40 PVC plastic pipe.

COMMENTS AND ACTION

715.02(i) Underdrain Outlet Pipe
 715.02(l) Roadway Drain Casting Extensions
 907.16 Thermoplastic Pipe Requirements
 907.24(b) Schedule 40 PVC Pipe

DISCUSSION:

Mr. Reilman introduced and presented this item stating that one of the three material options listed for roadway drain casting extensions is not available. To get back to the original intent of having three different allowable materials, a change is needed.

Mr. Reilman proposed to change the requirement for the plastic pipe from that stated (smooth wall PVC) to PVC pipe in accordance with 907.24(b).

There was no further discussion and this item passed as submitted.

<p>Motion: Mr. Reilman Second: Mr. Novak Ayes: 10 Nays: 0 FHWA Approval: YES</p>	<p>Action:</p> <p><input checked="" type="checkbox"/> Passed as Submitted <input type="checkbox"/> Passed as Revised <input type="checkbox"/> Withdrawn</p>
<p>2024 Standard Specifications Sections referenced and/or affected: 715.02(i) and 715.02(l) pg. 736 and 737; 907.16 pg. 1031; 907.24(b) pg. 1034.</p>	<p><input checked="" type="checkbox"/> 2026 Standard Specifications Revise Pay Items List Notification to Designers if change is <u>not</u> addressed by RSP</p>
<p>Recurring Special Provisions or Plan Details: NONE</p>	<p><input checked="" type="checkbox"/> Create RSP (No. 715-R-764) Effective: December 1, 2023</p>
<p>Standard Drawing affected: NONE</p>	<p><input type="checkbox"/> Revise RSP (No. __) Effective:</p>
<p>Design Manual Sections affected: NONE</p>	<p><input type="checkbox"/> Standard Drawing Effective:</p>
<p>GIFE Sections cross-references: NONE</p>	<p><input type="checkbox"/> Create RPD (No. __) Effective:</p>
	<p><input type="checkbox"/> GIFE Update <input checked="" type="checkbox"/> Frequency Manual Update <input type="checkbox"/> SiteManager Update</p>